

Spray lubricator EQS & Brush cleaner LBE

Make it two: A strong team for the press shop

Two machines – one control unit – maximum efficiency

Spray Lubricator EQS

Eckardt Quality Spraying: the next generation
Suitable for material widths up to 4.500 mm

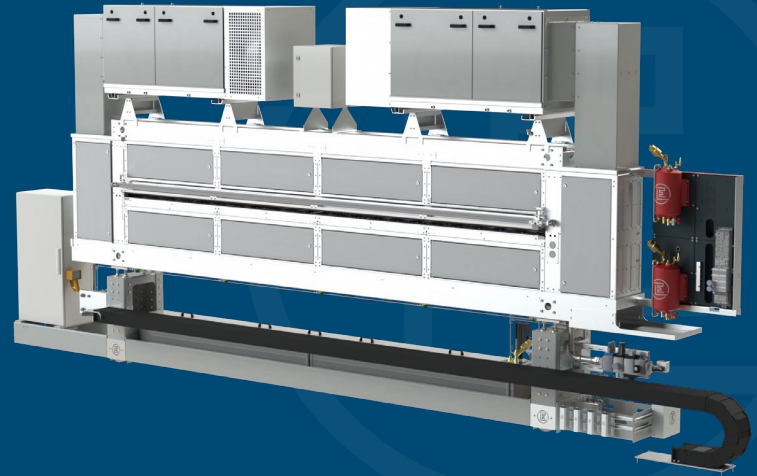

- **Precise integration:** Shortened overall length for uncomplicated integration into existing installation space, ideally suited for retrofit requirements.
- **Improved occupational/environmental protection:** Greatest possible reduction of oil mist in the ambient air, significantly longer filter service life (pre-filtering already in the extraction section, extraction at the bottom/top).
- **Minimal maintenance effort:** Good accessibility to all machine areas, overall longer maintenance intervals due to detail optimization at many points in the design (including flanged nozzles).
- **Flexible control integration:** Integration into many common control systems: Siemens S7, Siemens TIA Portal, Allen Bradley, Beckhoff, Bosch Rexroth...
- **Economically attractive:** After comprehensive training, instruction by us, commissioning, service at the end user are completely in your hands!
- **Fast delivery:** Construction in a modular system ensures attractive delivery times - even with tight lead times and tight supply situation!

Spray lubricator EQS: Side view

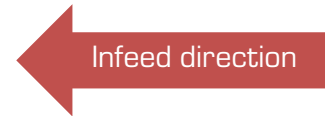
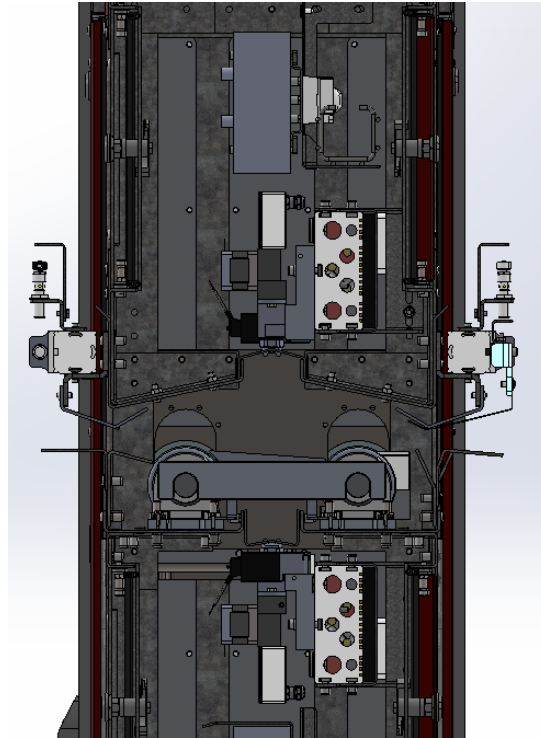

Spray lubricator EQS: Drive unit

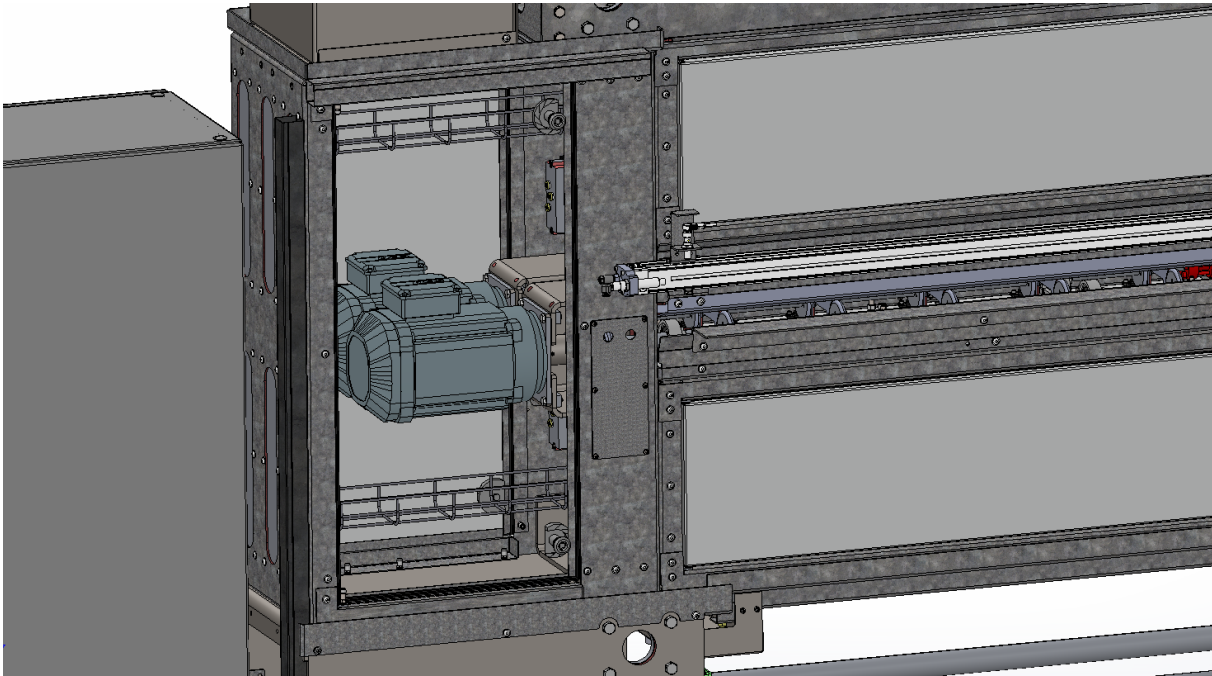

Spray lubricator EQS: Oil supply

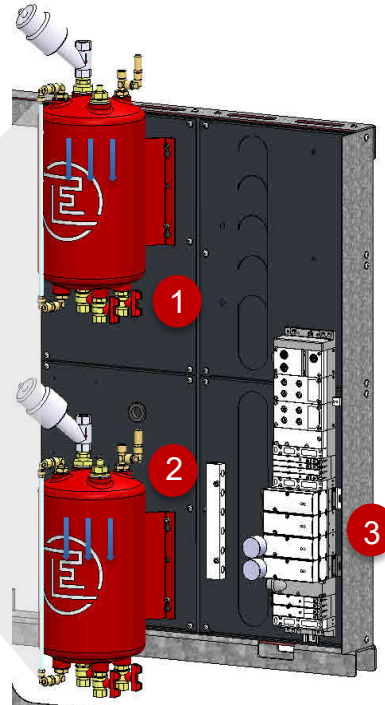
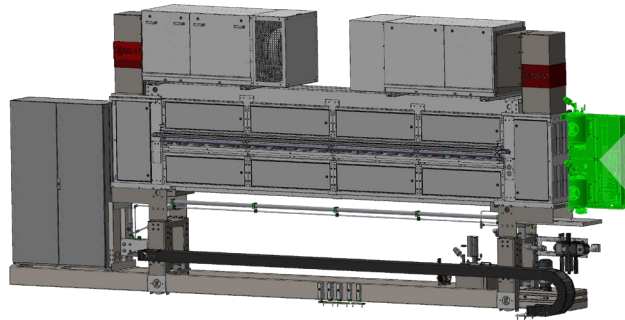

- **1** Pressure container for oil supply of upper spray bar
- **2** Pressure container for oil supply of lower spray bar
- **3** Valve terminal
- Compressed air pressure equals oil pressure.
- Changing the preload of compressed air changes the oil pressure accordingly.
- The higher the preload of compressed air, the more oil flows.

Standard oil circulation – one oil grade

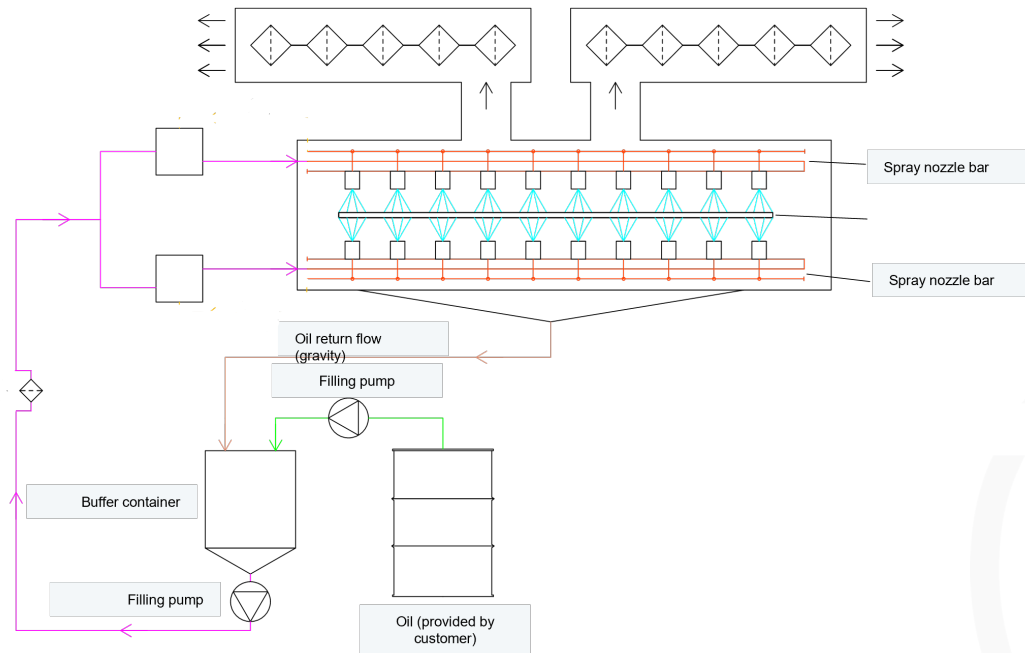

Standard oil circulation – two oil grades

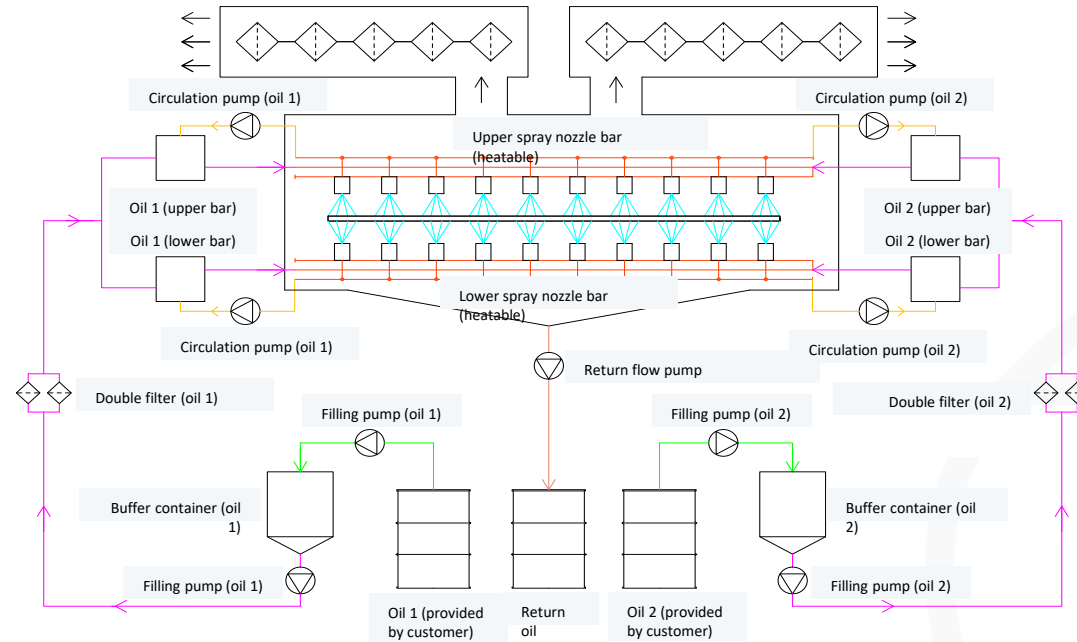



- Configuration for use with one oil grade

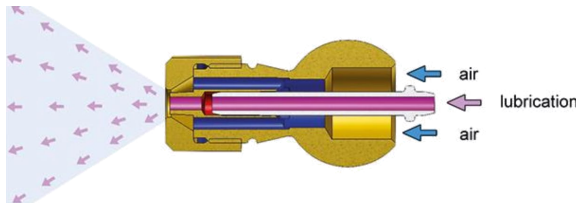

- A spray jet is generated from the interplay between control air, material feed pressure and spray air. It can take the form of either an intermittent or continuous spray process. Depending on which air cap is used, the spray output may be flat or round.
- The control air is supplied to the spray valve via a pilot valve. The spray air is supplied directly to the spray valve via a second air line. The integrated spray air control closes the spray air opening in the basic position.
- Once the pilot valve receives the signal, the front section of the needle piston chamber is flooded with air.
- The air valve is then pushed backwards on the needle against the needle guide, opening the spray air supply. Now the needle is pushed back and opens the nozzle.

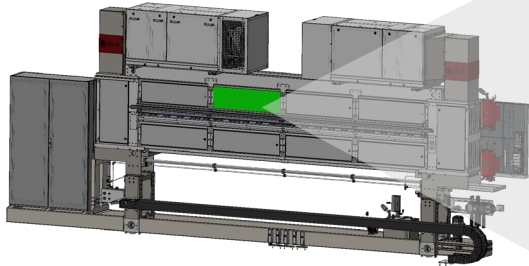

- Spray chamber equipped with automatic spray nozzles SDA 30

Spray lubricator EQS: Automatic spray nozzles SDA 30 – Principle of operation

- The nozzle needle of the SDA 30 is connected to a step motor with excenter, making the outflow rate continuously adjustable.
- The nozzle needs approx. 20 ms to change from “locked” to “completely open”. Each position in between is reached faster relative to this time span.
- Together with the pressure of the lubricant this enables the nozzle to apply different lubricant quantities to individual spray areas and to ensure particularly high throughput rates.
- The SDA 30 realizes layer thicknesses from $< 1 \text{ g/m}^2$ up to $> 5 \text{ g/m}^2$.

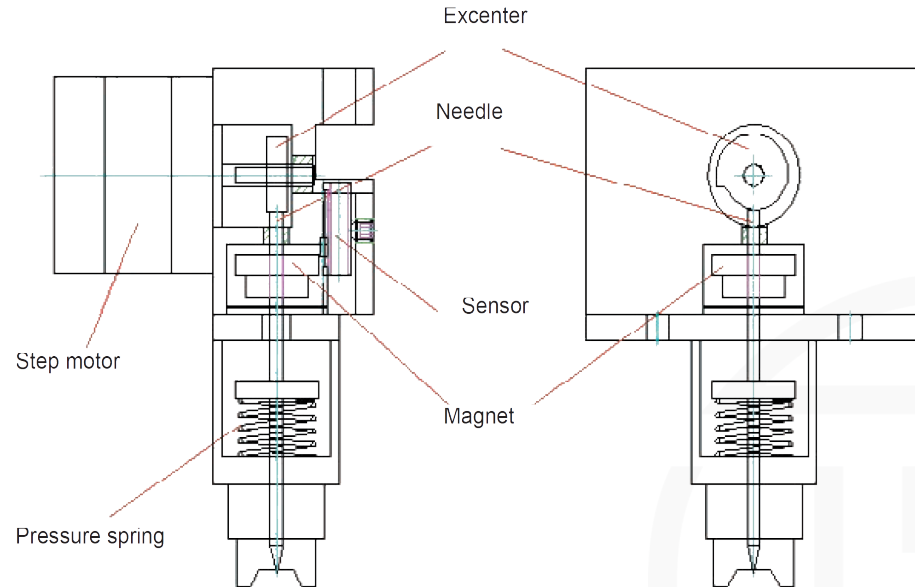

Spray lubricator EQS: Transport roller with wiper

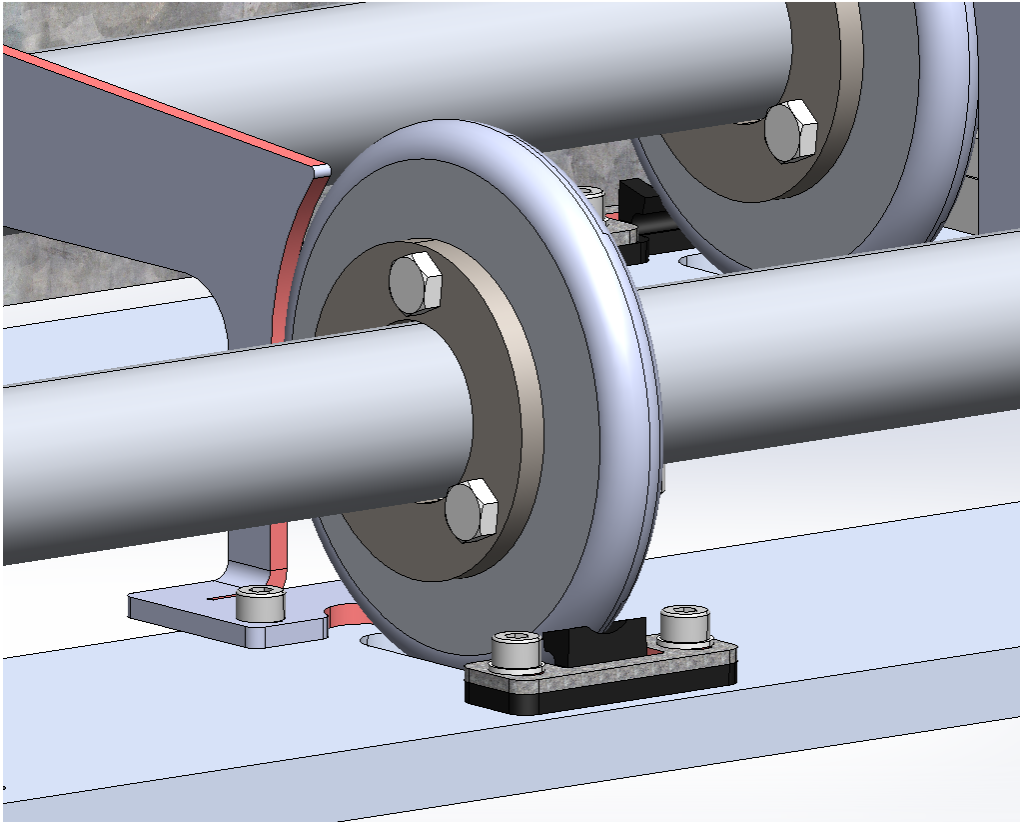

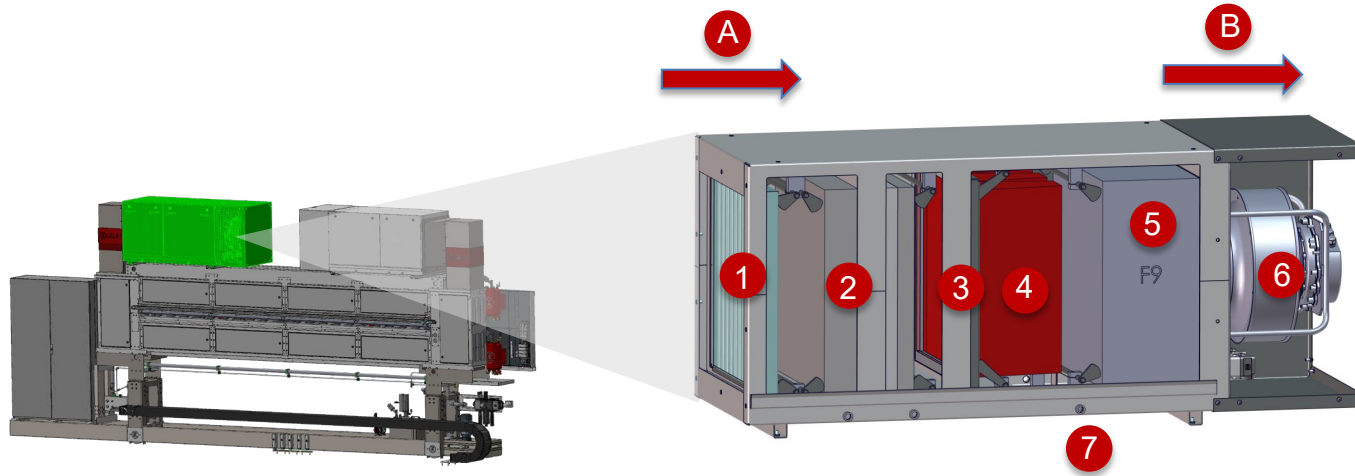

- **1** Filter stage 1: Lamella filter (Cleaning possible)
- **2** Filter stage 2: Wire mesh filter (Cleaning possible)
- **3** Filter stage 3: Wire mesh filter (Cleaning possible)
- **4** Filter stage 4: V-cell filter VF7 (Replacement only)
- **5** Filter stage 5: Final filter F9 / H13 (Replacement only)
- **6** Fan
- **7** Filter locking
- **A** Air intake
- **B** Air outlet

Brush cleaner LBE

Resource-efficient, thorough, low-wear

Suitable for material widths up to 4.500 mm



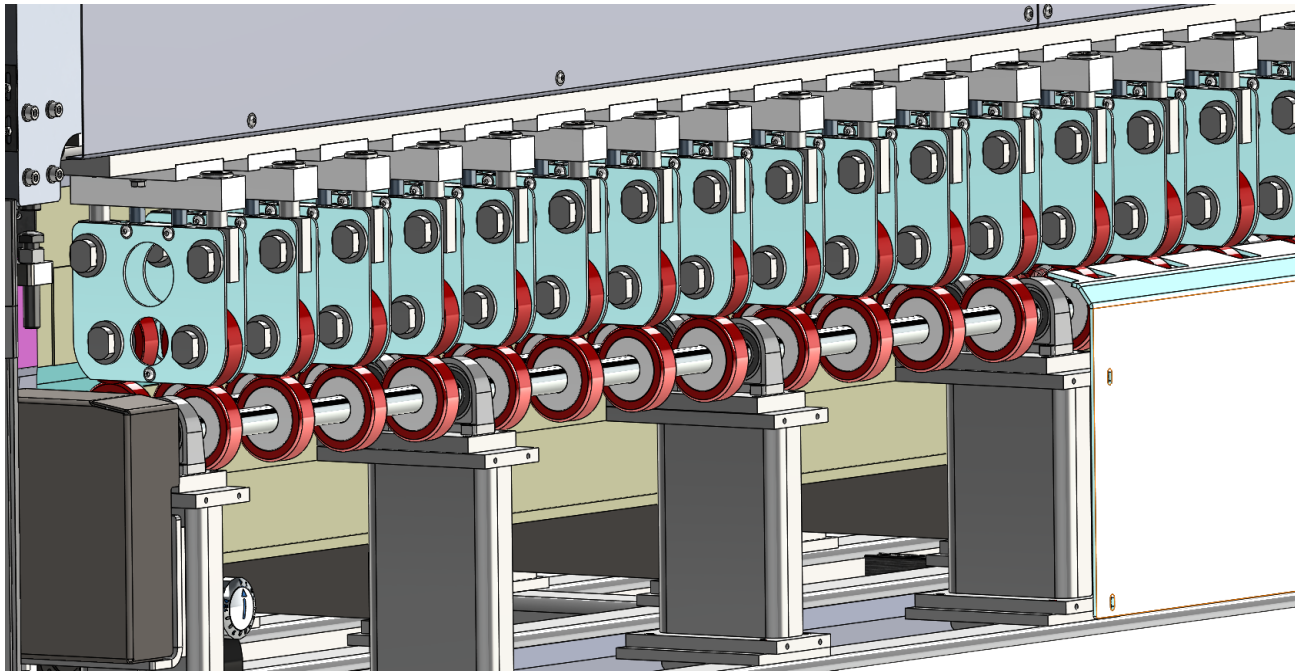

Brush cleaner LBE: Side view

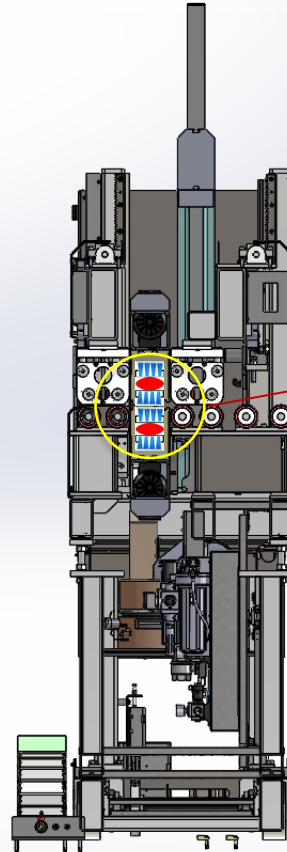

Insert: Brush with bristle correction system

Brush cleaner LBE: Transport rollers

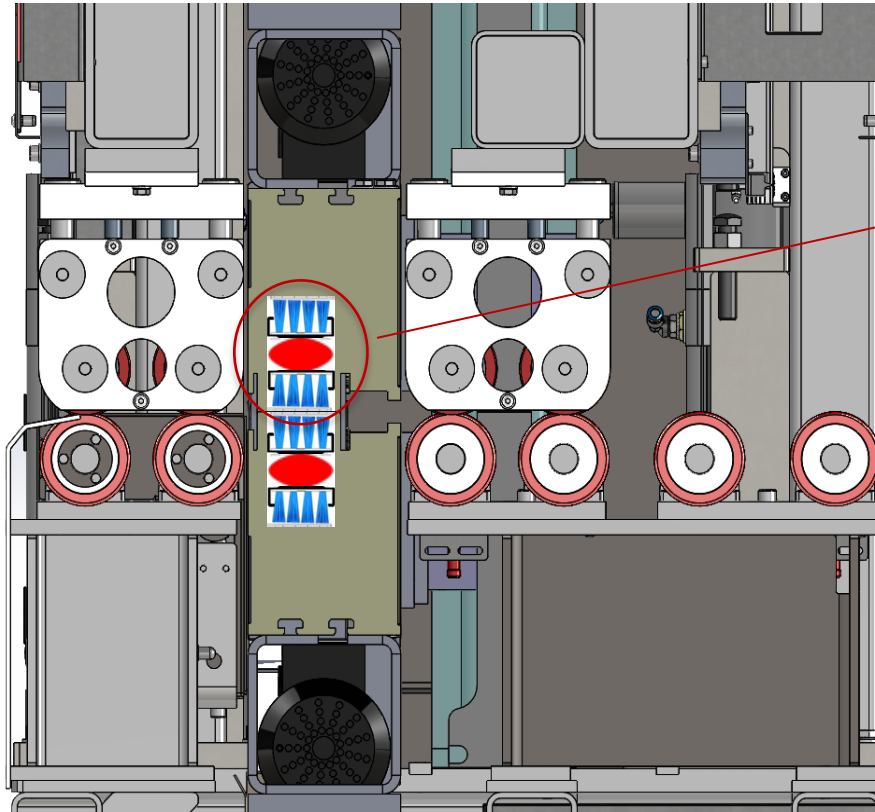

Insert: Brush with bristle correction system (see below)

Brush cleaner LBE: Bristle correction system

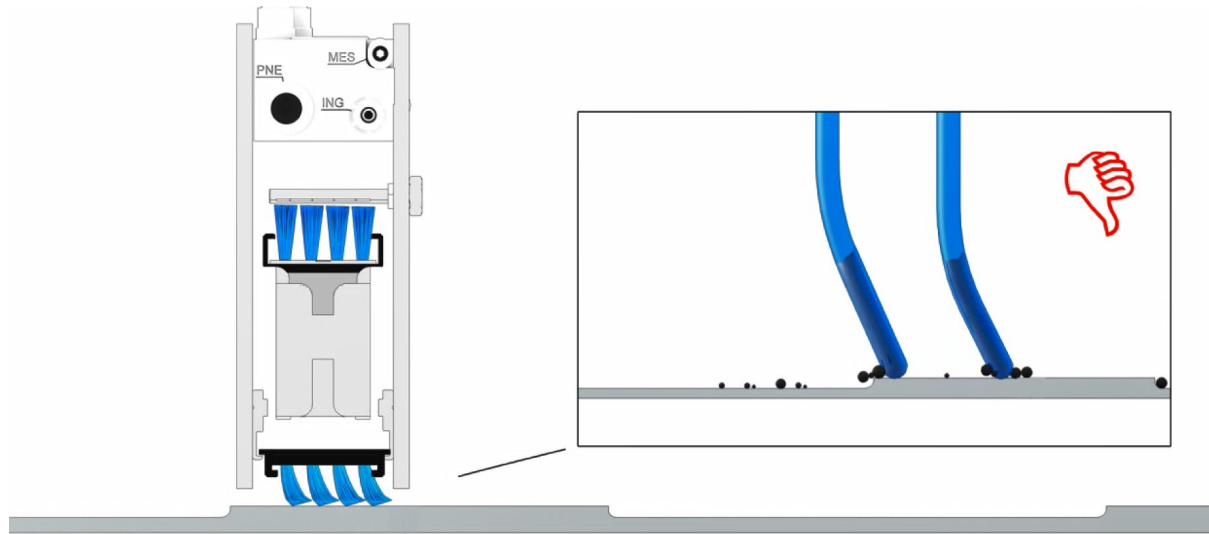

- While processing metal blanks of varying thickness, e.g. tailored blanks, the brush bristles may be pushed out of their upright position enabling dirt particles to slip through.
- As a result, the overall cleaning quality deteriorates and the bristles are likely to wear out prematurely.

Brush cleaner LBE: Bristle correction system

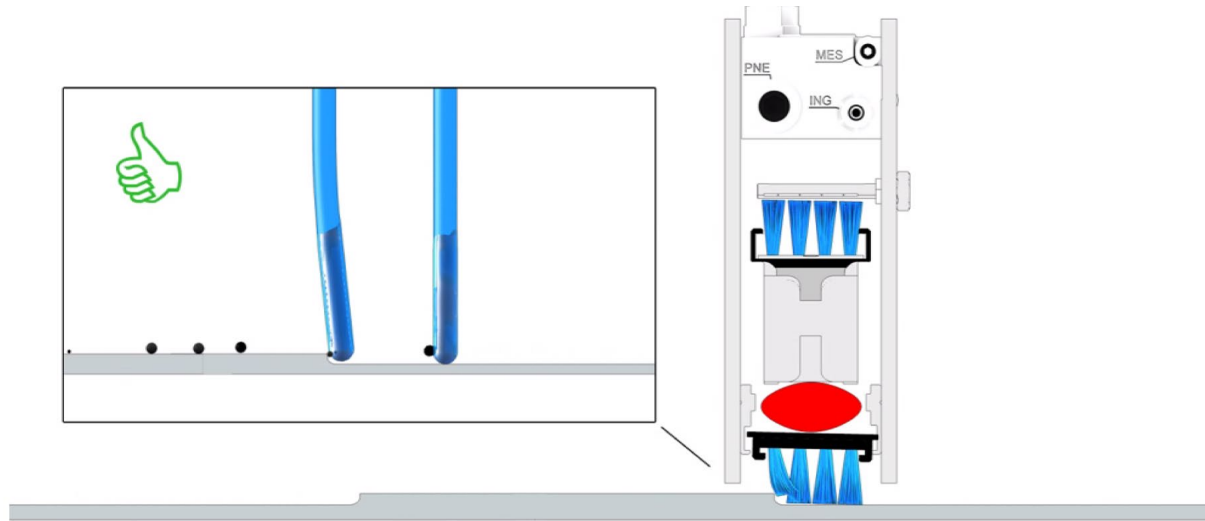

- This is where the pressure buffer comes into play, which is effectively an air cushion located right underneath the under brush guide.
- By applying a counter pressure on the under brush the buffer keeps the bristles in their upright position, so that dirt particles cannot slip through.
- No electronic brush adjustment or measurement of bristle length is required.

Brush cleaner LBE: Addition of cleaning fluid

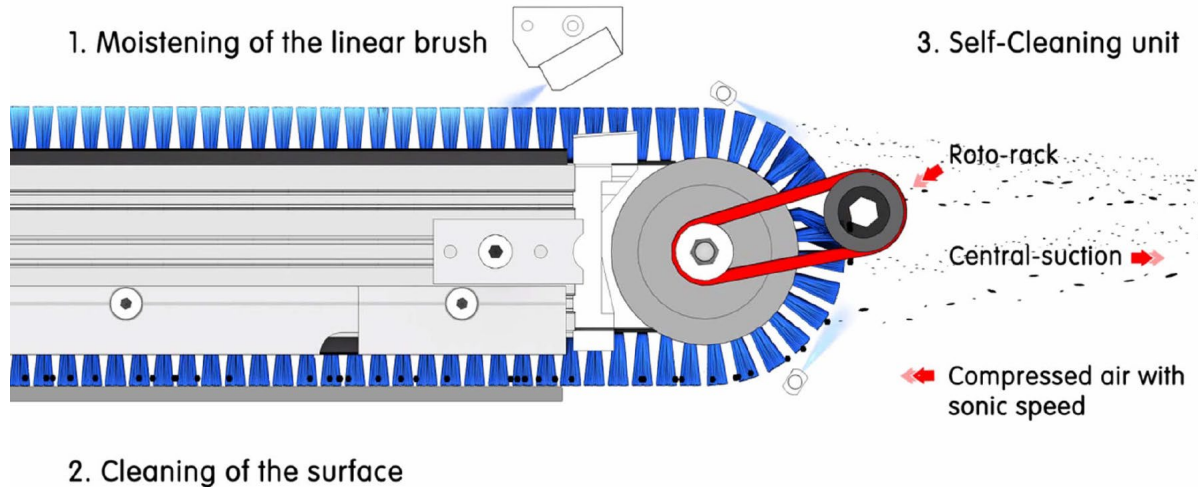

- Moistening of the rotating brush filaments with antistatic cleaning fluid for better adhesion of dirt particles
- The particles are thoroughly absorbed from the material surface and conveyed to a suction system.
- The self-cleaning of the circulating sword brush is performed by a rotating rack and compressed air nozzles.
- A suction system then disposes of the detached particles, efficiently preventing them from being discharged into the ambient air.

Brush cleaner LBE: Height adjustment

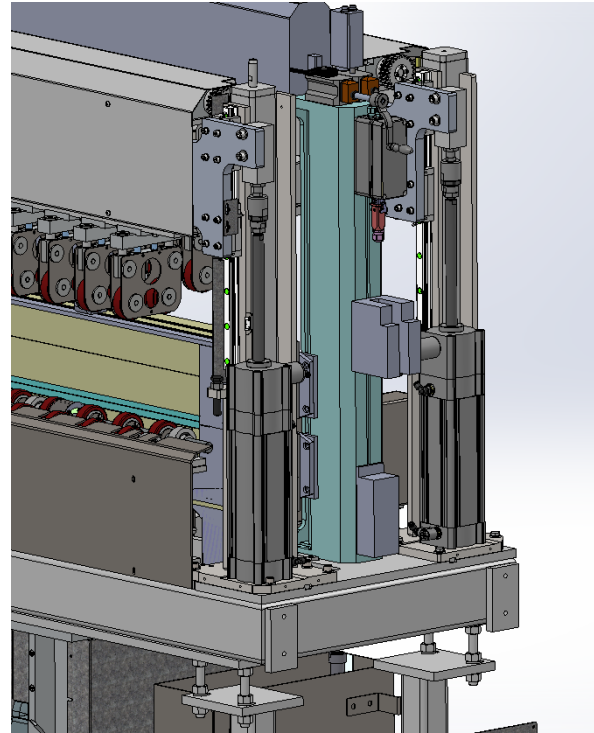
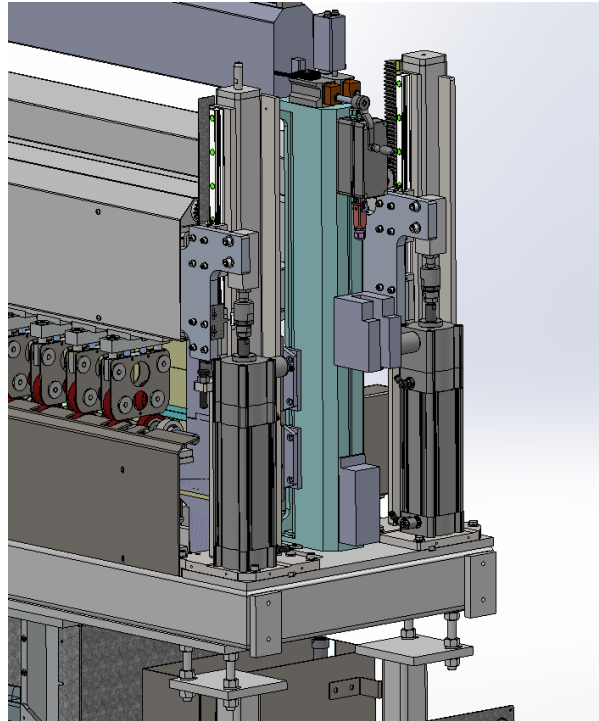

- Brush position „open“ for easy maintenance access

Brush cleaner LBE: Drive and supply unit

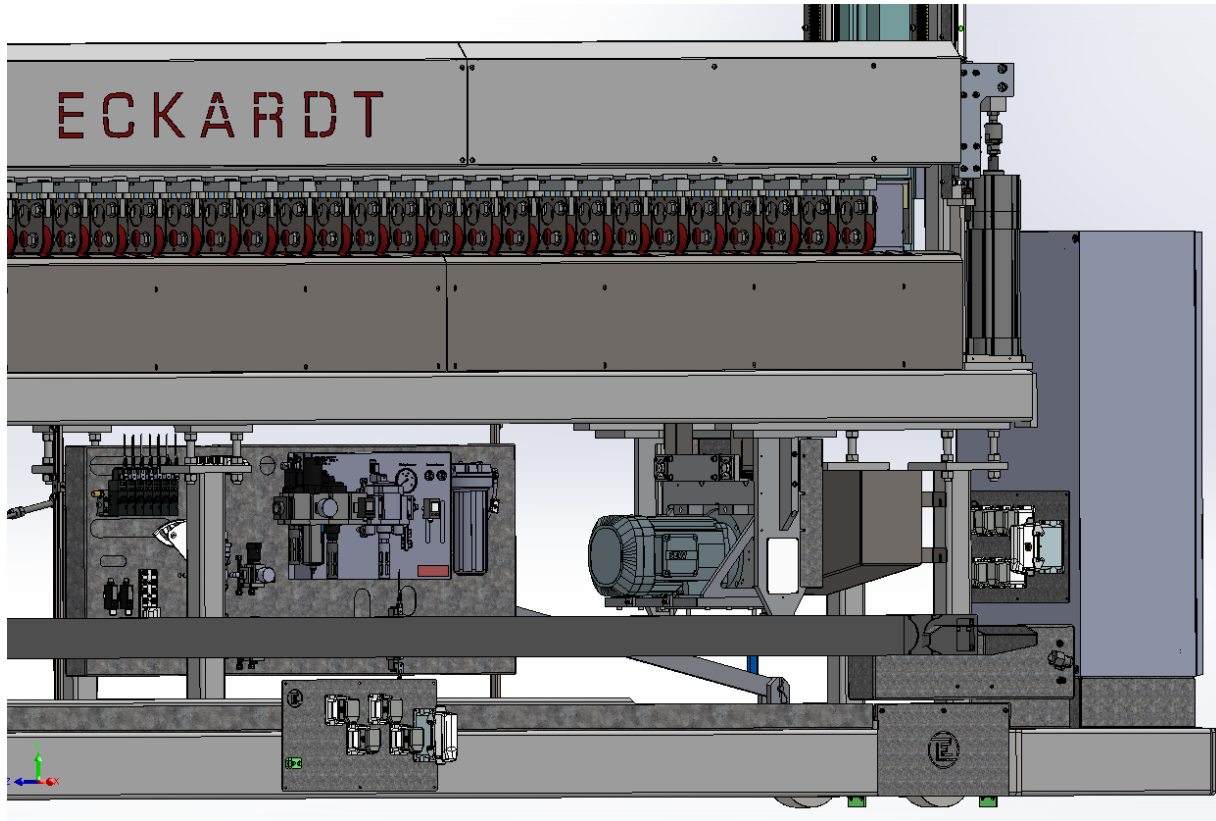

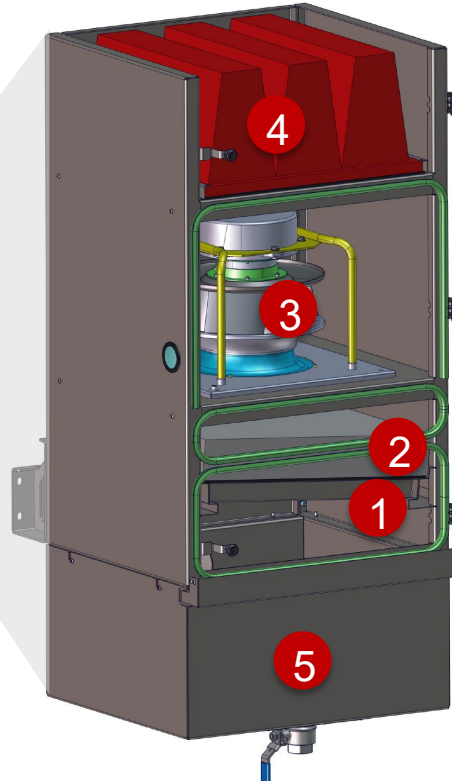
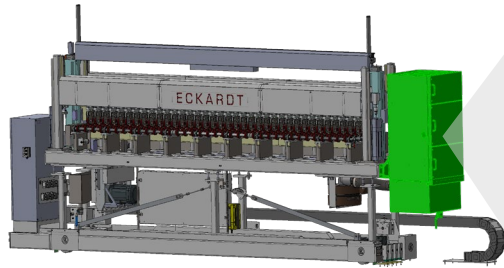

- **1** Lamella filter / pre-filter
(Cleaning possible)
- **2** Wire mesh filter
(Cleaning possible)
- **3** Radial fan
- **4** Final filter H13
(replacement only)
- **5** Drip tray

Spray lubricator EQS & Brush cleaner LBE



Two machines – One control unit

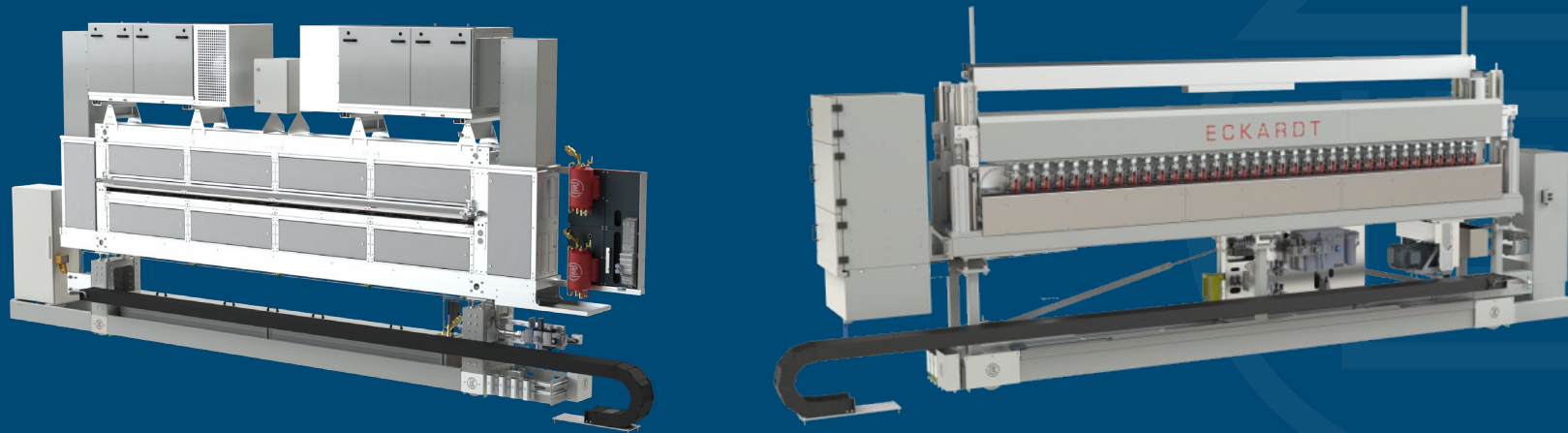

Spray lubricator EQS: Control software - Main screen

Sprayeditor - R1.00.0528

File Machinedata Documentation System Konfig SPS Bits

-V -U -T -S -R -Q -P -O -N -M -L -K -J -I -H -G -F -E -D -C -B -A +B+C+D+E+F+G+H+I+J+K+L+M+N+O+P+Q+R+S+T+U+V

0

+200

+400

+600

+800

+1000

+1200

+1400

+1600

+1800

+2000

+2200

+2400

+2600

+2800

+3000

+3200

+3400

+3600

+3800

+4000

+4200

-2050

-1750

-1450

-1150

-850

-550

-250

0

+250

+550

+850

+1150

+1450

+1750

+2050

0%

100%

READY

Synoptic

PLC NOT ACTIVE

3800

Nozzle +S

0%

0%

Beltspeed 0 m/min

Direction

DXF Import

Draw blank shape

Delete pattern

Active program

Workpiece No.

Lubrication No.

Transfer

Loaded program

Workpiece No. 0

Lubrication No. 01

Program Name

Muster

Blanksize

Length 4100 mm

Width 4100 mm

Temperature

Top 0 40 °C

Bottom 0 40 °C

Airpressure 0,0 0,5 bar

Oilpressure 0,0 0,5 bar

Lubrication

each 1 blank

Top Bottom

Oilwiper 1 blank

Spray lubricator EQS: Control software – Import of DXF files

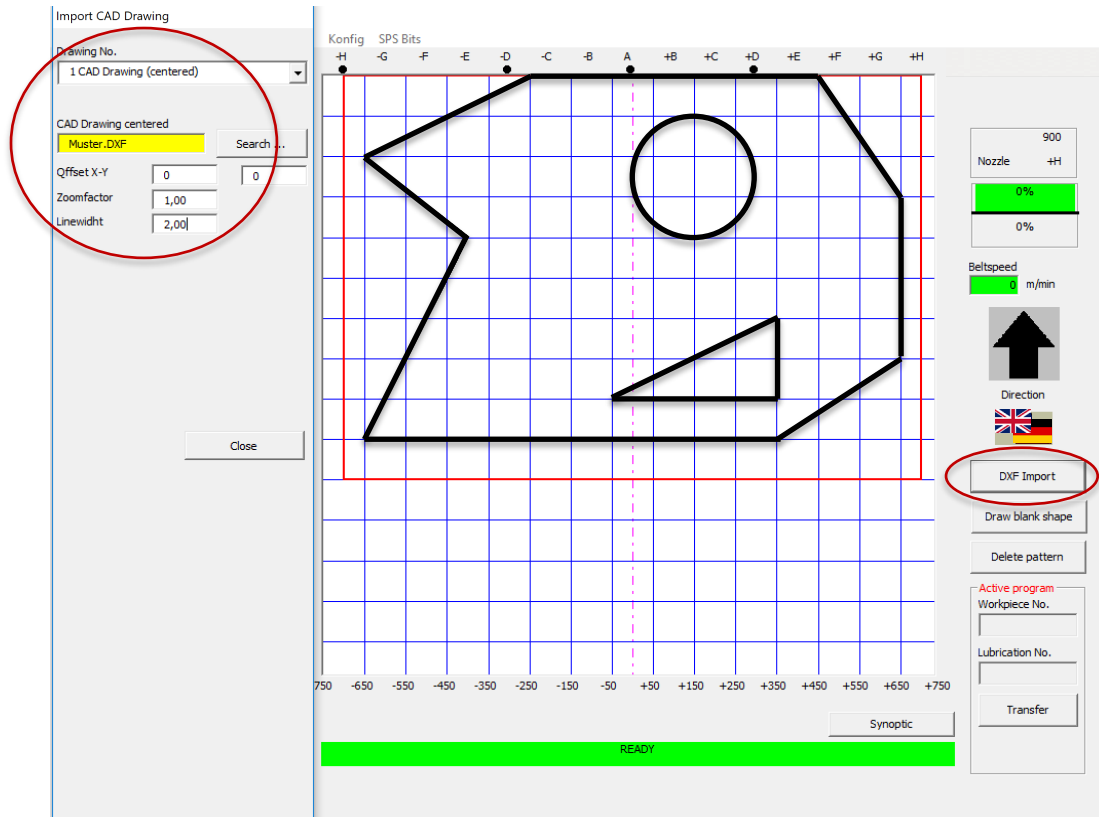

- The import of DXF (DWG) dimensional drawings facilitates the application of lubricants only where it is really needed.
- Via „Offset X-Y“ and „Zoomfactor“ you can adjust position and size of the drawing in relation to the plate size.
- For better visibility, the line width of the drawing can also be altered.

Spray lubricator EQS: Control software – Assign spray patterns

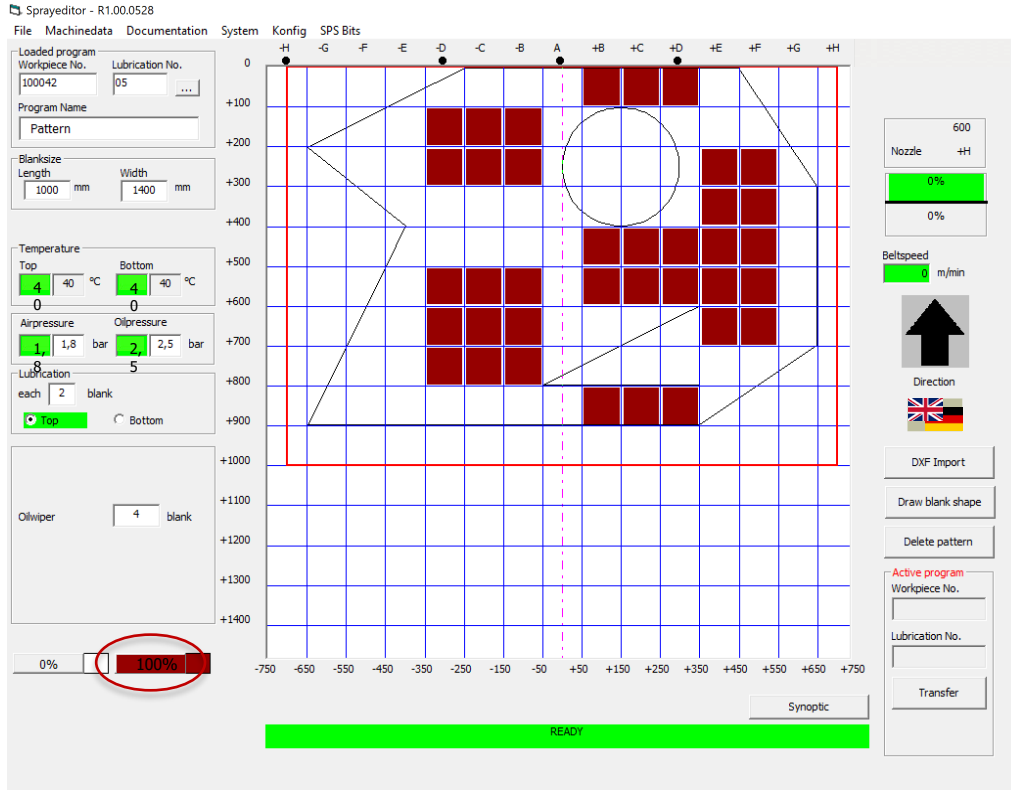

The screenshot shows the 'Sprayeditor - R1.00.0528' software interface. The main window displays a coordinate grid with X-axis labels from -750 to +750 and Y-axis labels from 0 to +1400. A complex spray pattern is overlaid on the grid, consisting of several red rectangular fields and a central circle. The pattern is defined by a black outline. The interface includes several control panels:

- File Machinedata Documentation System Konfig SPS Bits** (top menu)
- Loaded program** section: Workpiece No. (100042), Lubrication No. (05), Program Name (Pattern).
- Blanksize** section: Length (1000 mm), Width (1400 mm).
- Temperature** section: Top (40 °C), Bottom (40 °C).
- Airpressure** (1,8 bar) and **Oilpressure** (2,5 bar) section.
- Lubrication** section: each (2 blank), Top (selected) or Bottom.
- Oilwiper** section: 4 blank.
- 0% 100%** slider at the bottom left, with '100%' highlighted in a red circle.
- READY** status bar at the bottom.
- Right sidebar controls:** Nozzle (600, +H), Beltspeed (0 m/min), Direction (UK/DE flags), and buttons for 'DXF Import', 'Draw blank shape', 'Delete pattern', and 'Transfer'.

- To activate fields in the grid, click on „100%“
- To set a spray pattern, click on the individual fields or hold down the left mouse button and drag across the grid.

Spray lubricator EQS: Control software – Assign spray patterns top/bottom

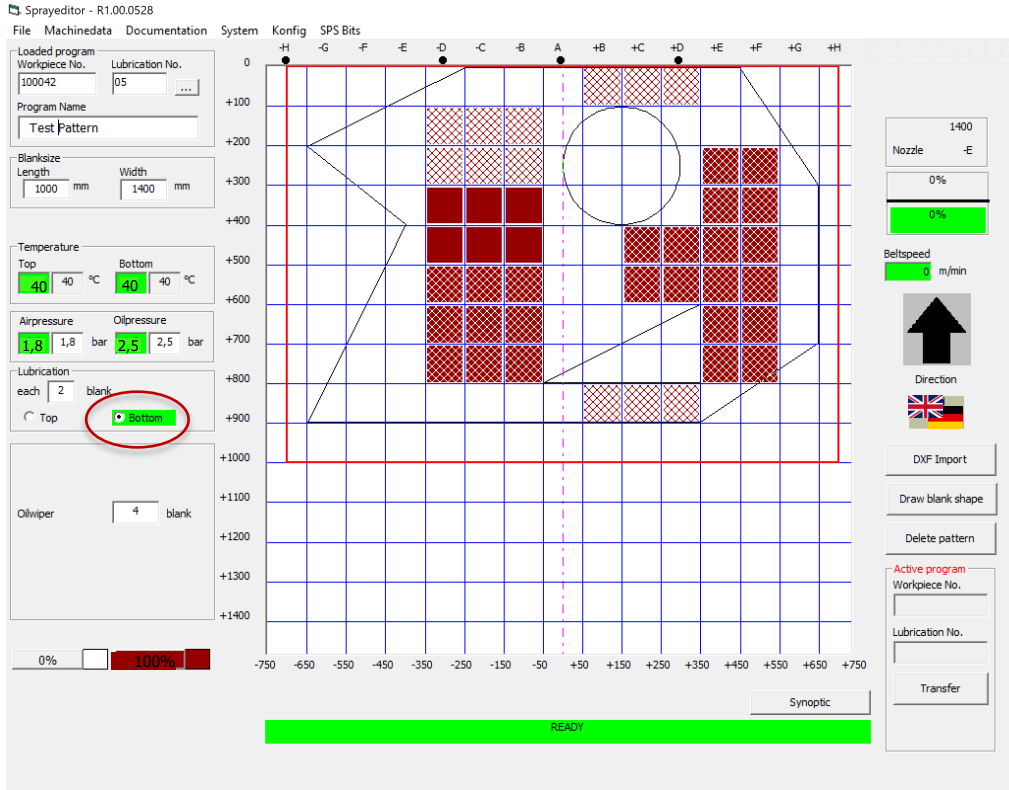

Sprayeditor - R1.00.0528

File Machinedata Documentation System Konfig SPS Bits

Loaded program: Test Pattern
Workpiece No.: 100042
Lubrication No.: 05

Blanks size: Length 1000 mm, Width 1400 mm

Temperature: Top 40 °C, Bottom 40 °C
Airpressure: 1,8 bar, Oilpressure: 2,5 bar

Lubrication: Top Bottom

Oilviper: 4 blank

0% 100%

READY

1400
Nozzle: -E
0%
Beltspeed: 0 m/min
Direction: 
DXF Import
Draw blank shape
Delete pattern
Active program
Workpiece No.:
Lubrication No.:
Transfer

- Spray patterns can be assigned to the top or bottom side of the plate.
- If you select “Bottom”, the spray fields already assigned to the top side are marked with bright criss-cross lines.
- If you select the same spray fields on the bottom side, the criss-cross lines turn dark.
- Spray fields which are only assigned to the bottom side are marked plain-coloured.

Spray lubricator EQS: Control software – Assign different spray grades

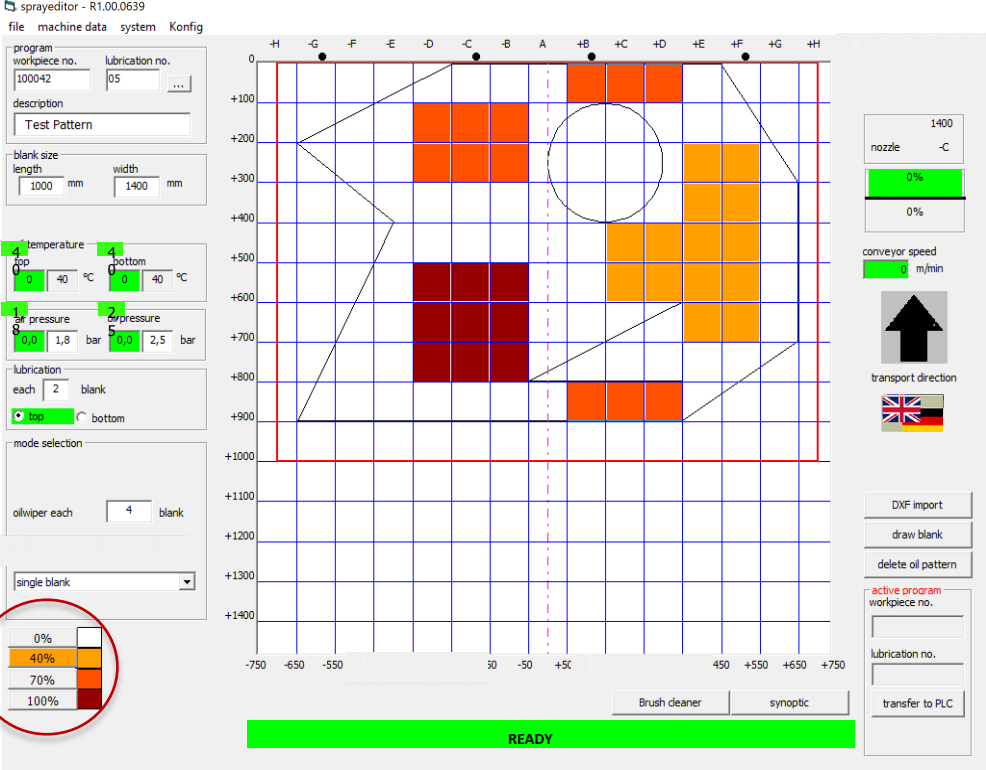

The screenshot displays the EQS control software interface. On the left, there are several configuration panels: 'program' (workpiece no. 100042, lubrication no. 05, description 'Test Pattern'), 'blank size' (length 1000 mm, width 1400 mm), 'temperature' (top 40°C, bottom 40°C), 'pressure' (1/1 10.0 bar, 2/2 2.5 bar), 'lubrication' (each 2 blank, top selected), and 'mode selection' (oilwiper each 4 blank, single blank selected). A legend in the bottom-left corner shows spray grade percentages: 0% (white), 40% (light orange), 70% (orange), and 100% (dark red). The main area is a grid with a central pattern of colored squares representing spray grades. The grid is labeled with letters H through +H and numbers 0 through +1400. A 'READY' indicator is at the bottom. On the right, there are controls for 'nozzle' (1400, -C), 'conveyor speed' (0 m/min), 'transport direction' (indicated by an upward arrow and a UK flag), and buttons for 'DNF import', 'draw blank', 'delete oil pattern', 'active program', 'workpiece no.', 'lubrication no.', and 'transfer to PLC'.

- Additional functionality includes the pre-selection of different spray grades.
- To assign a spray grade you need to activate one of the percentage buttons and click on the respective fields in the grid.
- The example shows the assignment of spray grades relative to the full lubricant quantity for each spray field.

Spray lubricator EQS: Control software – Assign different spray grades

sprayeditor - R1.00.0639
file machine data system Konfig

program
workpiece no. lubrication no.
100042 05

description
Test Pattern

blank size
length width
1000 mm 1400 mm

oil temperature
top bottom
4 40 °C 4 40 °C
0

air pressure oil pressure
1 1,8 bar 2 2,5 bar

lubrication
each 2 blank
top bottom

mode selection
oilwiper each 4 blank

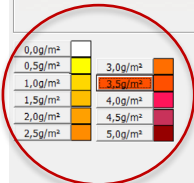

0,0g/m²
0,5g/m²
1,0g/m²
1,5g/m²
2,0g/m²
2,5g/m²
3,0g/m²
3,5g/m²
4,0g/m²
4,5g/m²
5,0g/m²

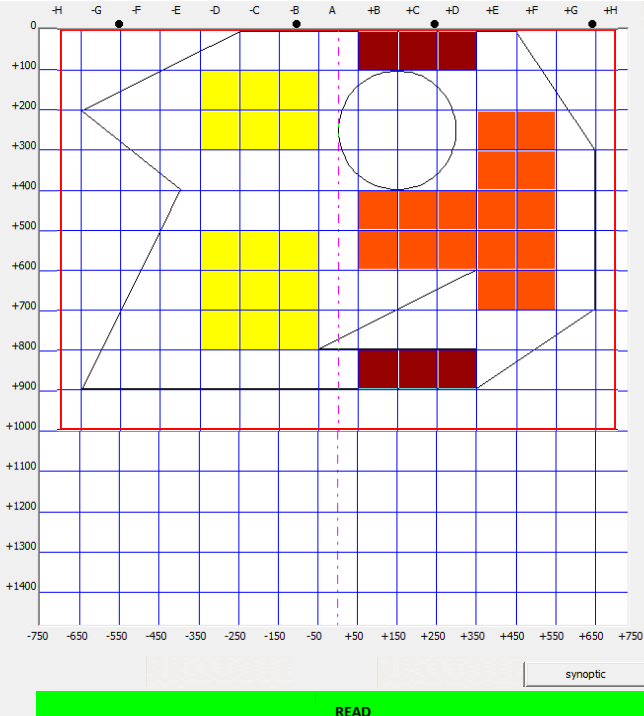

nozzle 1400
-C

0%
0%

conveyor speed
d m/min

transport direction
UK DE

DXF import
draw blank
delete oil pattern

active program
workpiece no.
lubrication no.
transfer to PLC

synoptic

- Option for use with automatic spray nozzles.
- With automatic spray nozzles, finer spray degrees can be assigned to the fields in grid.
- To assign a spray grade, one of the percentage buttons is activated and the corresponding fields in the grid are selected.
- The example shows the assignment of spray degrees based on defined lubricant quantities.

Spray lubricator EQS: Control software – Status indication

Synoptik Seite 0

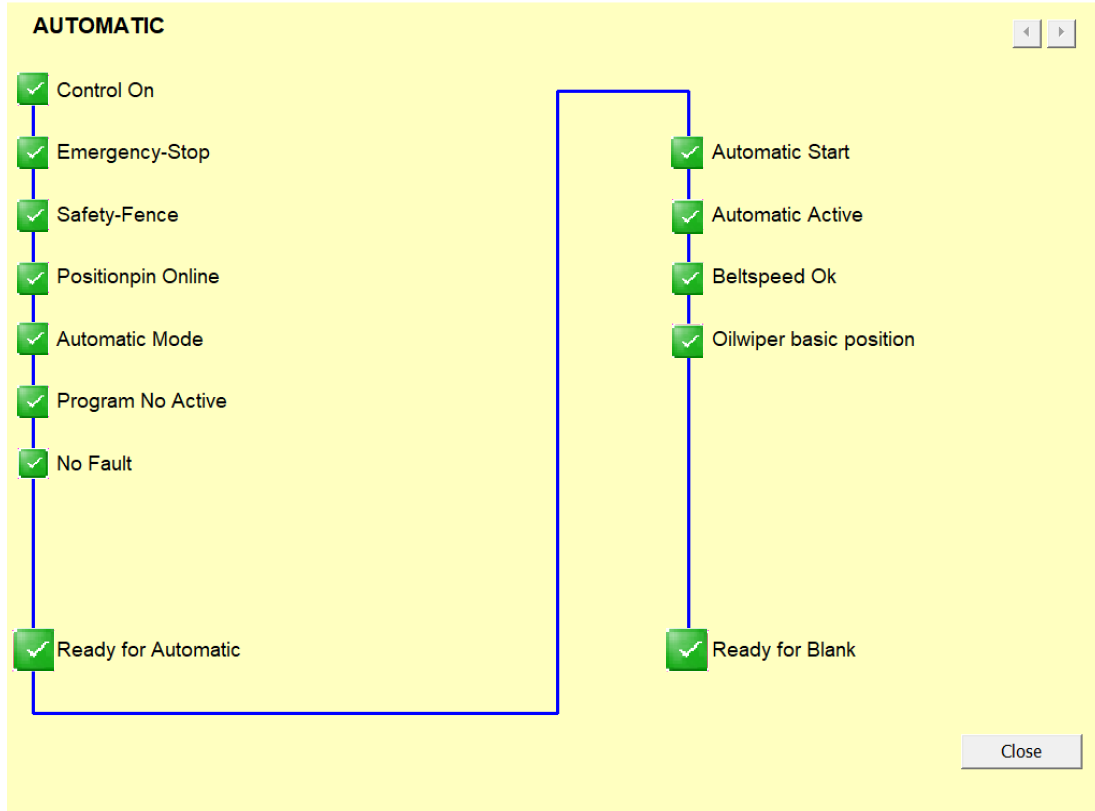

- The synoptik information window is used for initial fault localization.
- The conditions required for automatic operation are displayed here.

Spray lubricator EQS: Control software - Detailed malfunction indication

Stoegung Gesamtanlage

cabinet roiler+cleaner **reoler**

reoler

Safety PLC input modul = 9B+54TCA001	Safety load voltage L+41	Safety load voltage L+43		
Belt conveyor break fr =54-1950-Q002	Belt conveyor drive fault =54-1950-A001	Belt conveyor drive warning =54-1950-A001	Belt conveyor drive safety =54-1950-A001	Belt conveyor motor =54-54M0-M002
Belt conveyor speed =54-54M0-A001	Belt conveyor blank detection =54+54M0.8102-81019	[DI1] circulation pump =54-1950-Q005		[DI] heating fuse =54-1950-F001
Heating beam top sensor =54-54M0-E001	Heating beam top temperature =54-54M0-E001	Heating beam bottom sensor =54-54M0-E002	Heating beam bottom temperature =54-54M0-E002	
[DI1] heating top sensor =54-54M0-F001	[DI1] heating top temperature =54-54M0-F001			DI temperature top
[DI1] heating bottom sensor =54-54M0-F002	[DI1] heating bottom temperature =54-54M0-F002			DI temperature bottom
[DI1] oilbark level min =54-54M1-B001		[DI1] oilbark 100% =54-54M1-B003	[DI1] oilbark level min =54-54M1-B002	[DI1] oilbark level max =54-54M1-B002
[DI1] oilbark filltime =54-54M1-B002	[DI1] upper oilbark level min =54-54M0-B005	[DI1] upper oilbark level max =54-54M0-B005	[DI1] upper oilbark filltime =54-54M0-B005	[DI1] lower oilbark level min =54-54M0-B006
[DI1] lower oilbark level max =54-54M0-B006	[DI1] lower oilbark filltime =54-54M0-B006			
				Waste oil funnel level max =54-54M0-B011
Compressed air supply =54-54M0-B024	Sprayer pressure upper nozzle =91+54M0-A001-Y009	Sprayer pressure lower nozzle =91+54M0-A001-Y010	Sprayol pressure upper nozzle =91+54M0-A001-Y011	Sprayol pressure lower nozzle =91+54M0-A001-Y012
Suction left breaker =54-1950-Q003	Suction left prefilter =54-54M0-B001	Suction left endfilter =54-54M0-B002	Suction left fan =54-54M0-M003	
Suction right breaker =54-1950-Q004	Suction right prefilter =54-54M0-B003	Suction right endfilter =54-54M0-B004	Suction right fan =54-54M0-M004	
Oilwiper inlet side =54-54M0-8102/81021	Oilwiper outlet side =54-54M0-8102/81023			
Travel in/out =54-1950-Q001	Travel in/out position sensors =54+54M0-8101/81102			

Close fault reset

- Warnings (yellow) are only indicated, malfunction information (red) brings the system to a halt.
- For further information on the malfunction, click on the respective field.

Spray lubricator EQS: Manual switch



- The manual switch allows you to perform a function check for all spray nozzles.
- Using the thumbwheel switch, you can perform the nozzle test directly on the system.
- If a series of nozzles or all of them are selected, they will be switched on one after another as long as you keep the switch pressed.



■ Start screen



■ Abweichungsanalyse Luftdruck und



■ Düsenfunktionstest



■ Anzeige Fehlermeldung

Brush cleaner LBE: Control software - Main screen

sprayeditor - R1.00.0639



The screenshot shows the main control software interface for a brush cleaner. It features several control panels and status indicators:

- Program Information:** A panel with fields for "workpiece no." (0) and "lubrication no." (01), and a "description" field containing "Pattern".
- Speed Controls:** Three panels for "roller inlet side: speed", "roller outlet side: speed", and "upper brush: position". Each panel has "actual" and "set" values, both currently at 0, with units of m/min or mm.
- Blank Thickness:** A panel with a "set" value of 0,0 mm.
- Language:** A flag icon representing the United Kingdom.
- Buttons:** "Reoller", "synoptic" (circled in red), and "fault reset".
- Status Bar:** A green bar with the text "READY".
- Active Program:** A panel with fields for "workpiece no." and "lubrication no.", and a "transfer to PLC" button.
- Checkboxes:** An unchecked checkbox labeled "Ingramat".

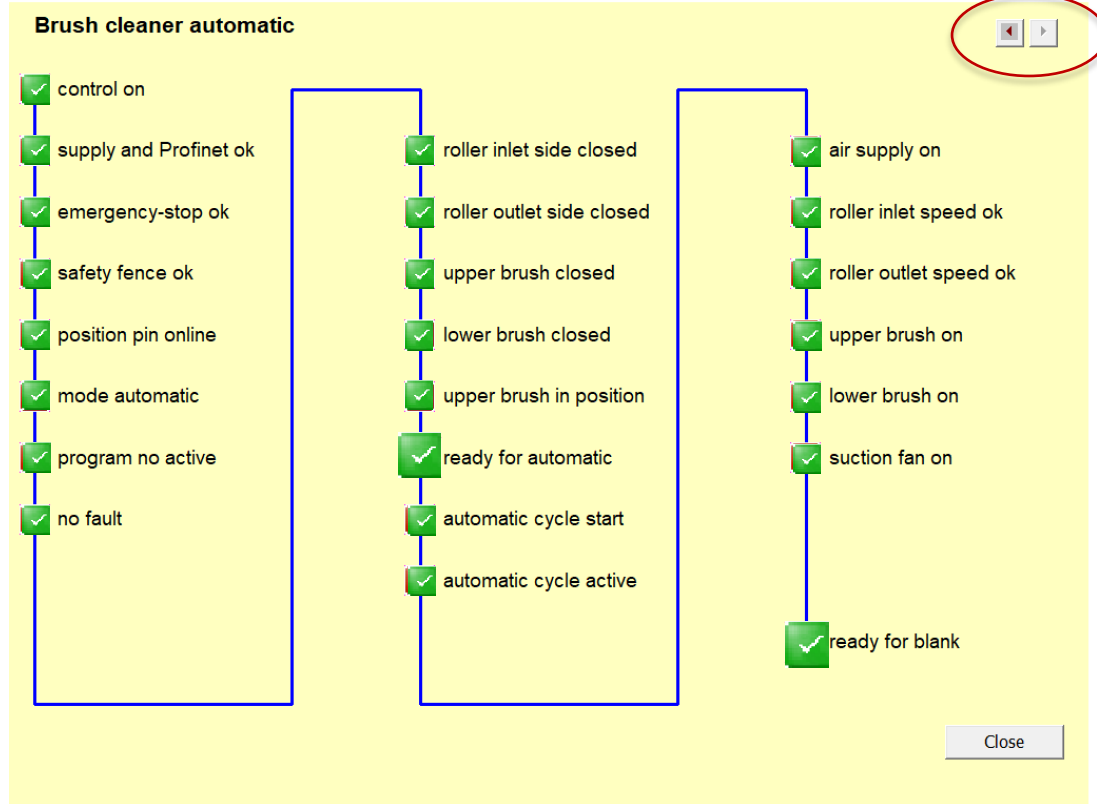

- The synoptic information window is used for initial fault localization.
- The conditions required for automatic operation are displayed here.
- Click on the arrow to change to the reoiler synopsis.

Spray lubricator EQS & Brush cleaner LBE



Sample drawings

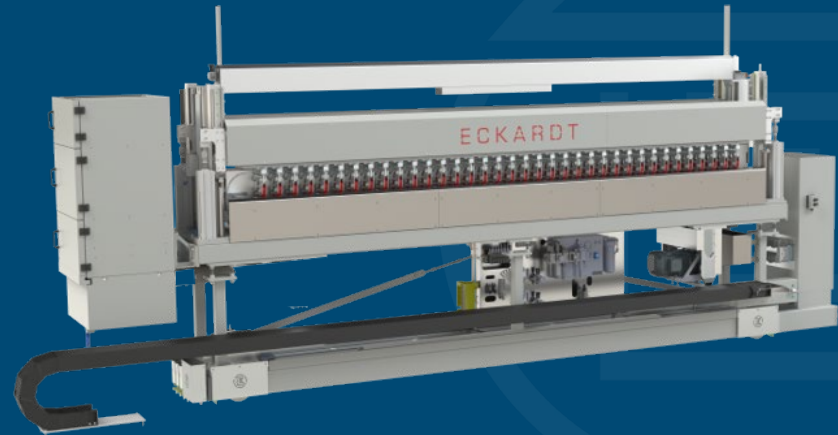
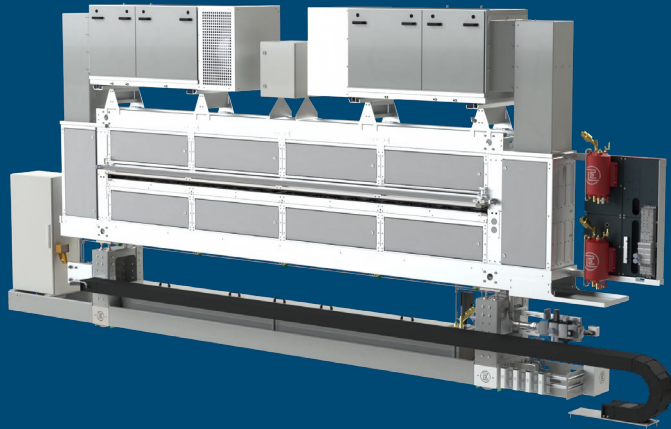

Spray lubricator EQS: Dimensions

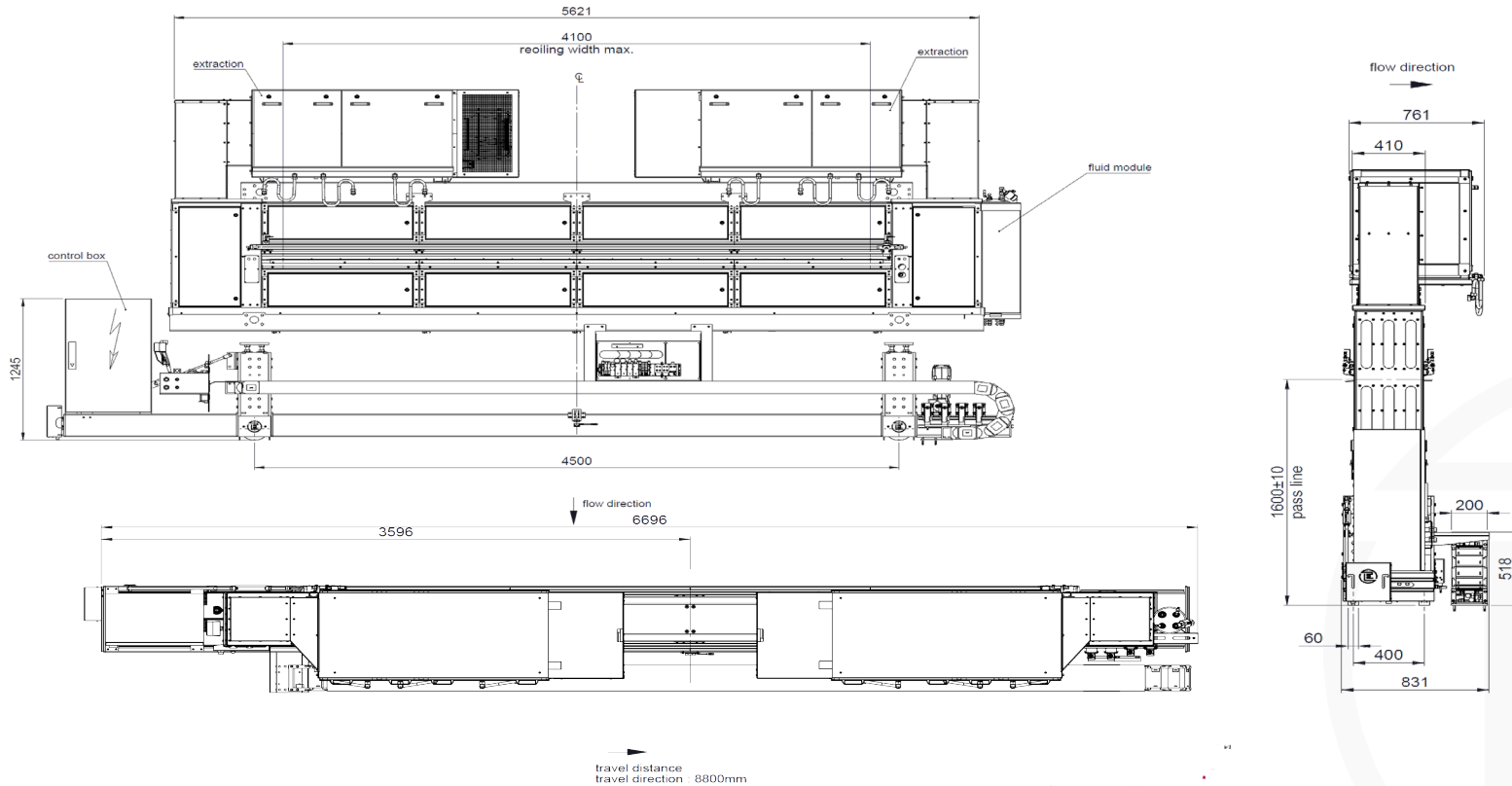

Brush cleaner LBE: Dimensions

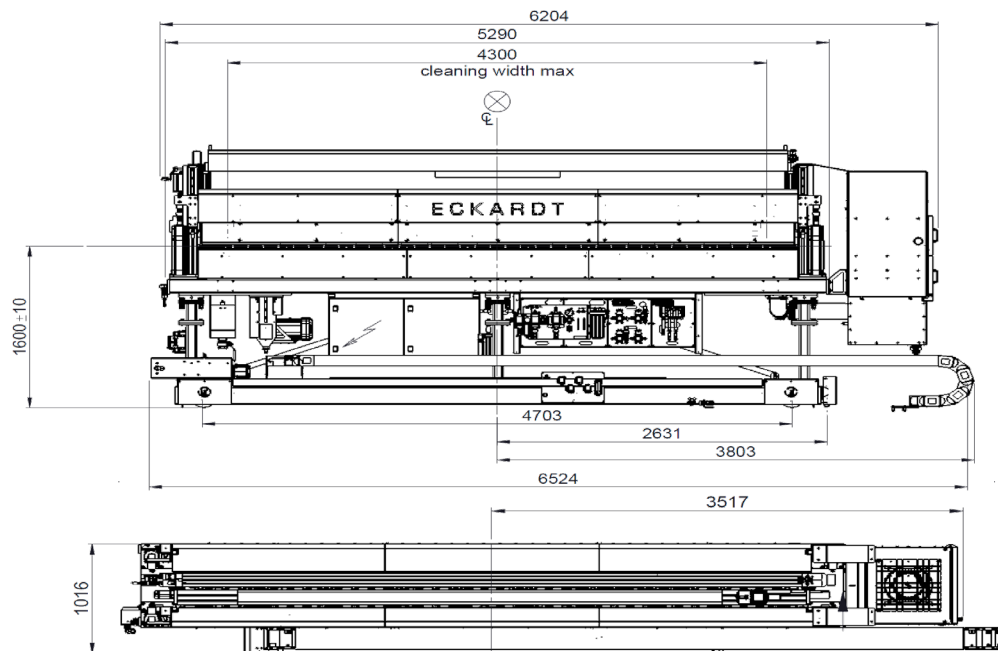

travel direction in maintenance position: →
travel distance: 10000

flow direction

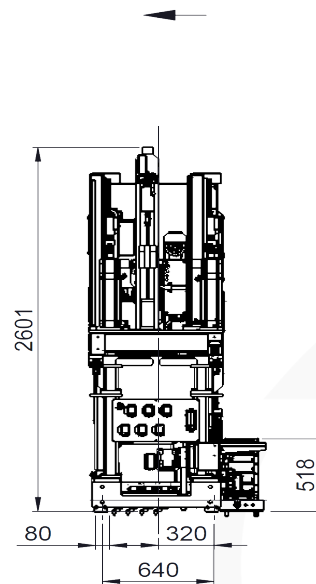

Spray lubricator EQS & Brush cleaner LBE: Dimensions combined

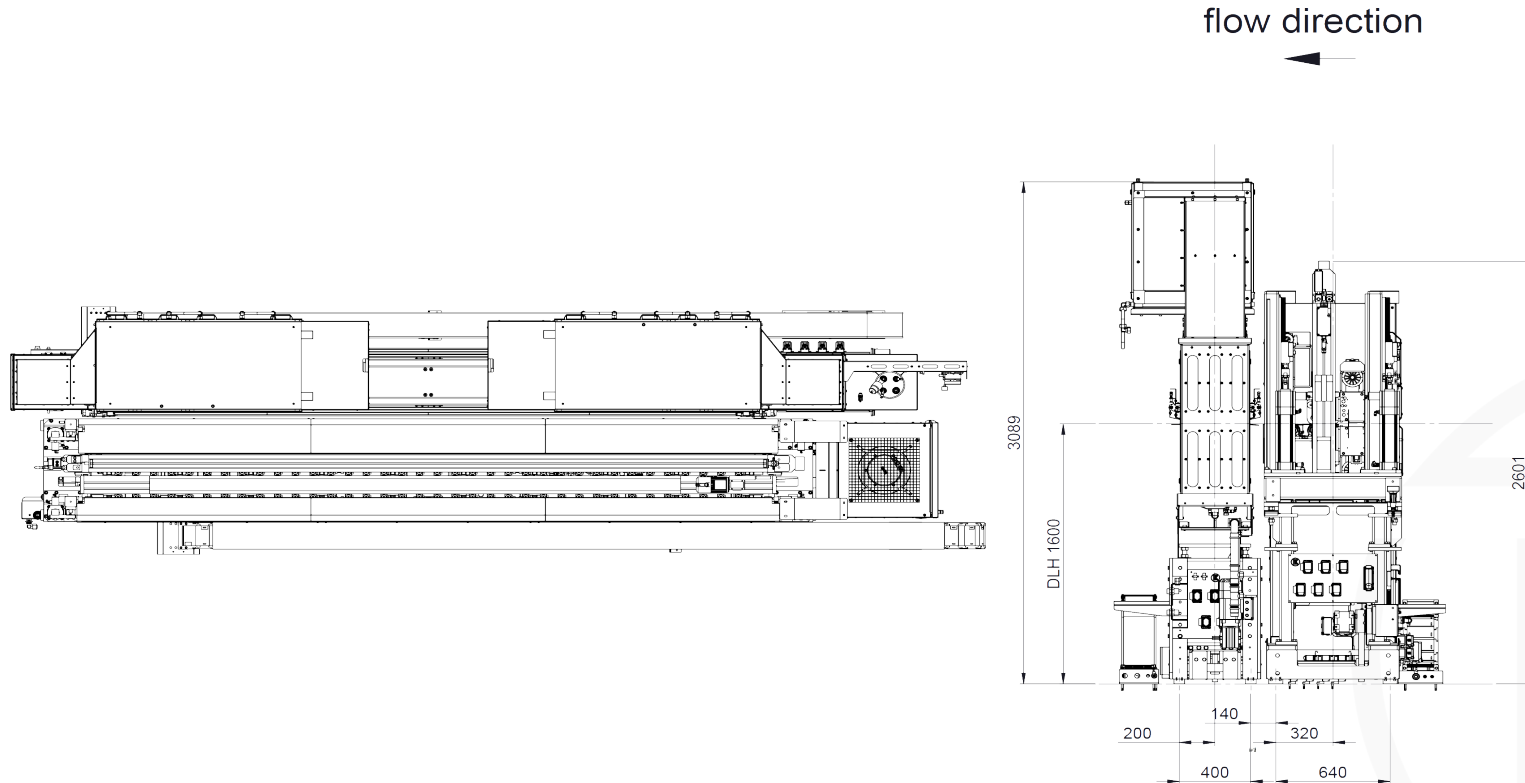

POMAC

Tel. +32(0)51316205
info@pomac.be

Goudenappelstraat 19
8780 Oostrozebeke

www.pomac.be



ECKARDT

Lubricating • Cleaning • Preserving

Eckardt Systems

