

DUAL LINE 02

DUAL LINE

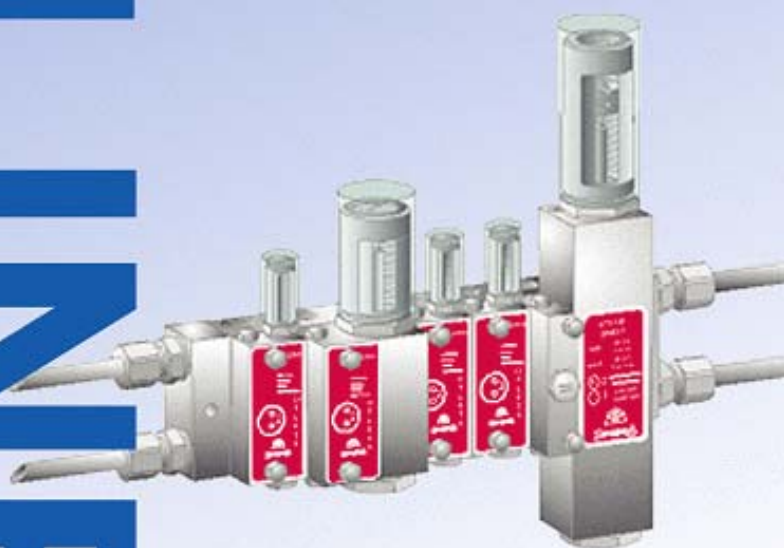

Centralised lubrication systems



POMAC
LUB SERVICES BVBA

Kortrijkstraat 187 B-8770 Ingelmunster
Tel. +32 (0)51 316 205 - Fax +32 (0)51 309 621 info@pomac.be - www.pomac.be

CONTENTS

Sheet No.	Description	Revision
A1	Feeder block series AP1	C1044IE
A5	Feeder block series APF05 – APF1	C1045IE
A8	Proximity Switch for Flow control	C1054IE
A10	Feeder block series AP6	C1062IE
A15	Feeder block series AP6F	C1061IE
A20	Feeder block series AG6	C1060IE
A25	Feeder block series AG6F	C1063IE
A30	Feeder block series AGG6	C1064IE
A35	Feeder block series AGG6F	C1065IE
A45	Double control matering valves	C1067IE
M1	Modular dual line	C1081IE

Pumps and accessories for use with Dropsa dual line system 02

B1	777000 series motorised pumps	C1073IE
B5	Trolley mounted motor driven pump 777000	C1074IE
B10	Modular motor driven pumps 999000	C1075IE
B30	Manual pumps series 156000	C1076IE
B40	Pump 242000 series	C2022PE
B50	Pump 765000 series	C2012PE
C1	Transfer and filling pumps series 132000	C1078IE
C20	Heavy duty pneumatic pumps series 400200	C1079IE
C25	Pneumatic transfer and filling pumps 72160	C1080IE
D1	Micro-switch for low control	C1082IE
D2	End of line pressure switch	C1083IE



FEEDER BLOCK SERIES AP1.

Adjustable Discharge 0,1 - 1 cc. per stroke
(.006 - .061 cu.in./stroke) Dual Line System

622200 623200
624200 625200
622260 623260
624260 625260

PRODUCT DATA SHEET

ENGLISH

DESCRIPTION:

The feeder body is made of special anti-friction steel. Pistons are made of hardened steel. Bores and pistons are lapped to provide superior sealing. The indicator turrets are provided with integral adjusting screws together with a metacrylate cover and seal.

On request an aluminium cover can be supplied. The feeder body has a galvanized finish and features an adaptor (see Fig. F.) for single or double outlet conversion.

SPECIFICATION:

Temperature range: -30 to +80°C.
Max. pressure (inlet): 400 bar (5800 psi.)
Cycles: 100/min.
Min. Viscosity: 100 cSt (462 SSU)
Grease Max.: 265 ASTM (NLGI 2)*
Connections:
Inlet: 1/4"
Outlet: 5/16" - 24NF

(*) For different type of grease please contact your supplier

ORDERING INFORMATION:

Ordering is by Part No., refer to the following table:

Thread	Part No.	Weight		No. Outlets
		Kg.	Lbs.	
Dropsa Standard BSP	622200	0,450	.99	1 - 2
	623200	0,660	1.45	2 - 4
	624200	0,900	1.98	3 - 6
	625200	1,10	2.42	4 - 8
NPTF	622260	0,450	.99	1 - 2
	623260	0,660	1.45	2 - 4
	624260	0,900	1.98	3 - 6
	625260	1,10	2.42	4 - 8

INSTALLATION/OPERATION:

Function:(Refer to Figs. 1 and 3.)The feeder discharge is controlled by a servo-piston (A) and metering piston (B) and can be arranged to



separate outlets. Fig. F. = connecting bridge for single outlet. Feeders are normally supplied with double outlets unless otherwise specified. For single outlets use Connecting Bridge **Part No. 622030** (refer to Fig. 3.).

The two outlets of each feeder block must always be used. If you need only one outlet you must use Connecting Bridge **Part No. 622030**. The other outlet cannot be plugged. The volume can be adjusted by turning the screw of the turret. When single outlet feeders are used, the discharge per complete cycle = 0,2 to 2 cc/stroke (.012 to .122 cu.in./stroke.).

Dimensions: (Refer to Fig. 2.).

Mounting: (Refer to Fig. 2.). Aluminium Bushings **Part No. 622017** are supplied for mounting on uneven surfaces to prevent distortion or damage due to overtightening.

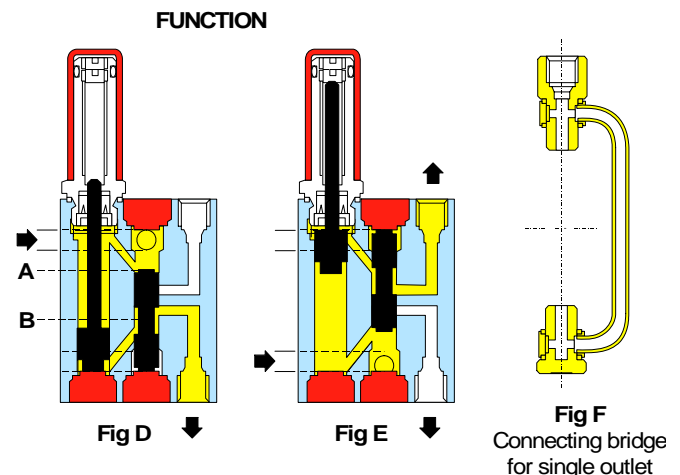

POMAC
LUB SERVICES BVBA

Kortrijkstraat 187 B-8770 Ingelmunster

Tel. +32 (0)51 316 205 - Fax +32 (0)51 309 621 info@pomac.be - www.pomac.be

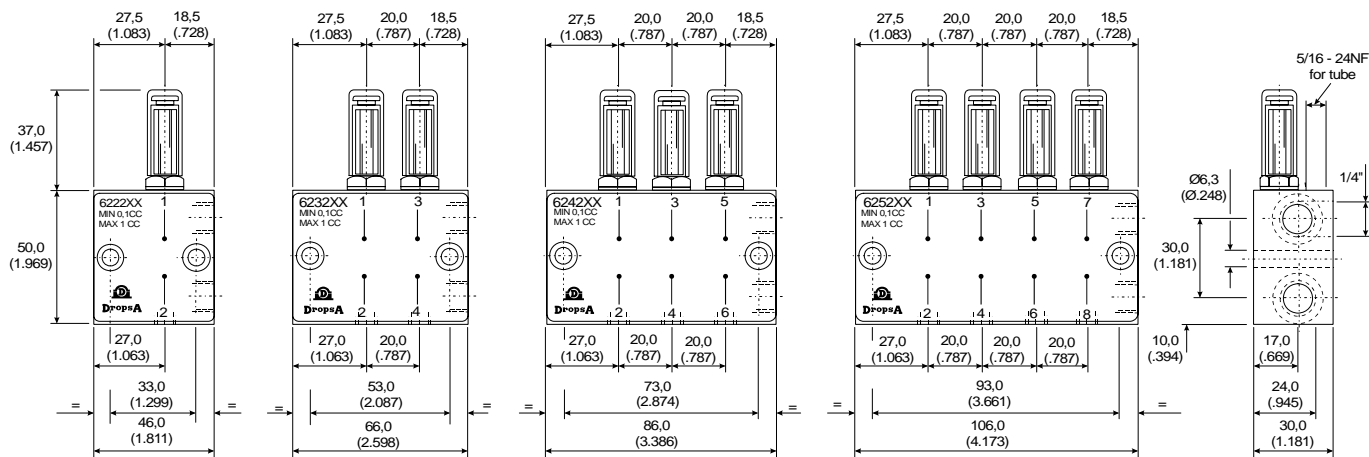

DROPSA STANDARD - DIN 3852 Ø mm				
Plug	Ø Tube	Nut	Ring	Fitting
926001	6	91396	91590	92337
	8	91402	91596	92266
	10	91406	91601	92242
NPTF DRY SEAL Ø INCHES				
850281	1/4	850200	850220	850250
	5/16	850201	850221	850252
	3/8	850202	850222	850254

DROPSA STANDARD - Ø mm			
Cone	Bush	Ø Tube	Plug
93004	92004	Ø4	91005
NPTF DRY SEAL Ø INCHES			
93004	92026	Ø 5/32	91005

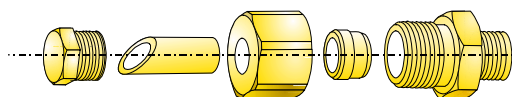
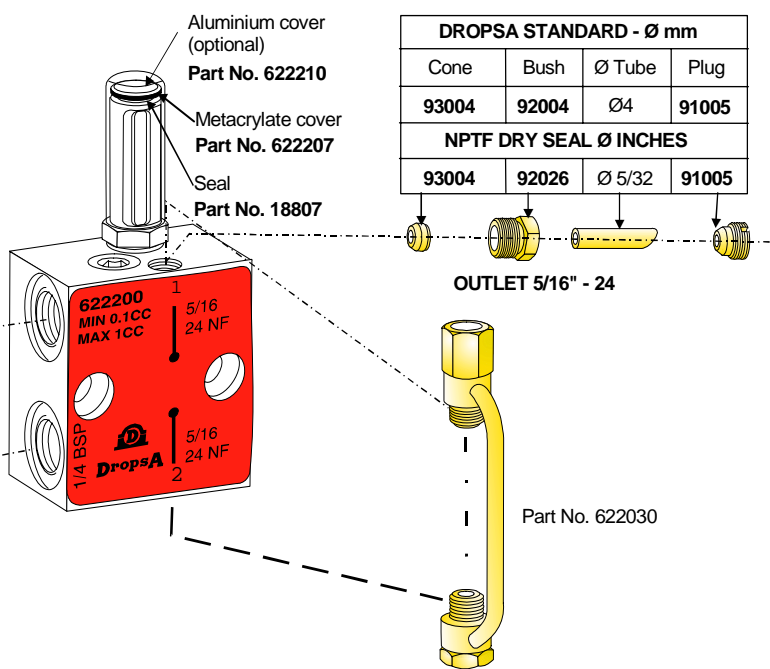

INLET 1/4"

WELD PLATES FOR FEEDERS

The fixing parts which are indicated thus * are to be ordered separately.

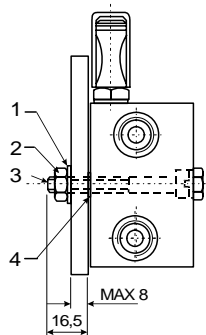

Pos	Part No.	Qty.	Description	
*1	16009	2	Spring washer	Metric
*2	16335	2	Nut M6	
*3	12534	2	Screw M6 x 45	
4	622017	2	Bushing	
*1	16012	2	Spring washer	Inches
*2	16499	2	Nut 1/4-28 UNF Hex. 7/16	
*3	12562	2	Screw 1/4-28 UNF x 1 3/4	
4	622017	2	Bushing	

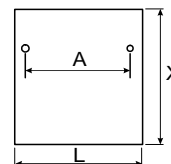
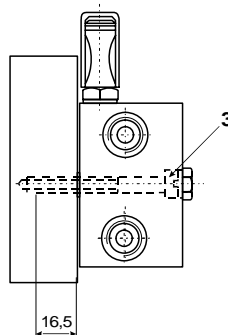

N.	Part No.	DIMENSIONS (INCHES)		
		A	L	X
1	111585	33 (1.29)	45 (1.77)	120 (4.72)
2	111586	53 (2.08)	65 (2.55)	120 (4.72)
3	111587	73 (2.87)	85 (3.34)	120 (4.72)
4	111588	93 (3.66)	105 (4.13)	120 (4.72)



POMAC
LUB SERVICES BVBA

Kortrijkstraat 187 B-8770 Ingelmunster

Tel. +32 (0)51 316 205 - Fax +32 (0)51 309 621 info@pomac.be - www.pomac.be



FEEDER BLOCK SERIES APF05-APF1

Fixed Discharge APF05 0,5 cc. APF1 1 cc. per/stroke
(APF05 .030 cu.in./stroke APF1 .061 cu.in./stroke)
Dual Line System.

622060 622070
623060 623070
624060 624070
625060 625070
622080 622090
623080 623090
624080 624090
625080 625090

ENGLISH

PRODUCT DATA SHEET

DESCRIPTION:

The feeder body is made of special anti-friction steel. Pistons are made of tempered steel. Bores and pistons are lapped to provide superior sealing. These feeders do not employ indicator turrets (see AP1 series) and are used for special applications. The body has a galvanized finish and features an adaptor (see Fig. F.) for single or double outlet conversion. They are set by the factory 0,5 cc. per/stroke (.030 cu.in./stroke) for APF05 and at 1 cc. per/stroke (.061 cu.in./stroke) for APF1 unless otherwise requested.



SPECIFICATION:

Temperature range: -30 to +80°C.
Max. pressure (inlet): 400 bar (5800 psi.)
Cycles: 100/min.
Min. viscosity: 100cSt (462 SSU)
Grease Max. 265 ASTM (NLGI 2)*
Connections:
Inlet: 1/4"
Outlet: 5/16"-24NF

Fig D-E = 2 separate outlets. Fig F = connecting bridge for single outlet.

Feeders are normally supplied with double outlets unless otherwise specified. For single outlets use Connecting Bridge **Part No. 622030 (refer to Fig. 3.)**. When single outlet feeders are used, the discharge per complete cycle = for APF05 0,5 - 1 cc./stroke (.030 - .061 cu.in./stroke) and for APF1 1 - 2 cc./stroke (.061 - .122 cu.in./stroke).

(* For different type of grease please contact your supplier

ORDERING INFORMATION:

Ordering is by Part No. refer to the following table:

Thread	Part No.		Weight.		No. Outlets.
	APF05	APF1	Kg.	Lbs.	
Dropsa Standard BSP.	622060	622070	0,430	.94	1-2
	623060	623070	0,620	1.36	2-4
	624060	624070	0,840	1.85	3-6
	625060	625070	1,00	2.20	4-8
NPTF	622080	622090	0,430	.94	1-2
	623080	623090	0,620	1.36	2-4
	624080	624090	0,840	1.85	3-6
	625080	625090	1,00	2.20	4-8

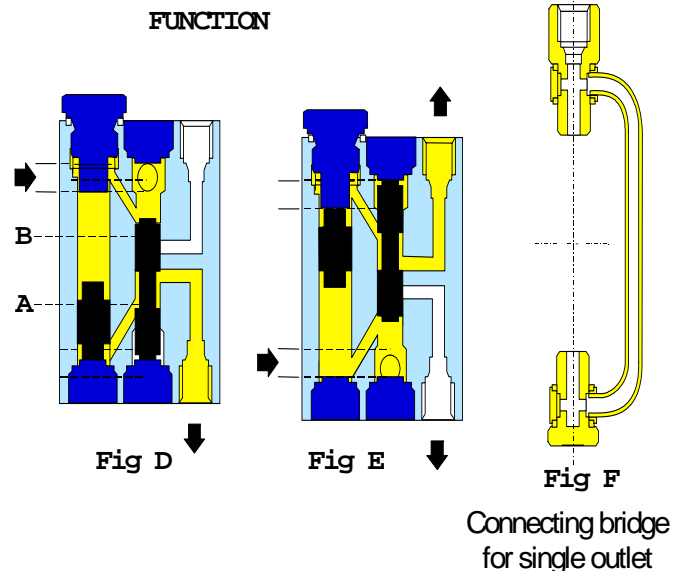

INSTALLATION/OPERATION:

Function:(Refer to Figs. 1 and 3.)The feeder discharge is controlled by a servo piston (A) and metering piston (B) and can be arranged to provide a single or double outlet.

Dimensions: (Refer to Fig. 2.)

Mounting: (Refer to Fig. 4.) Aluminium Bushings **Part No. 622017** are supplied for mounting on uneven surfaces to prevent distortion or damage due to overtightening.

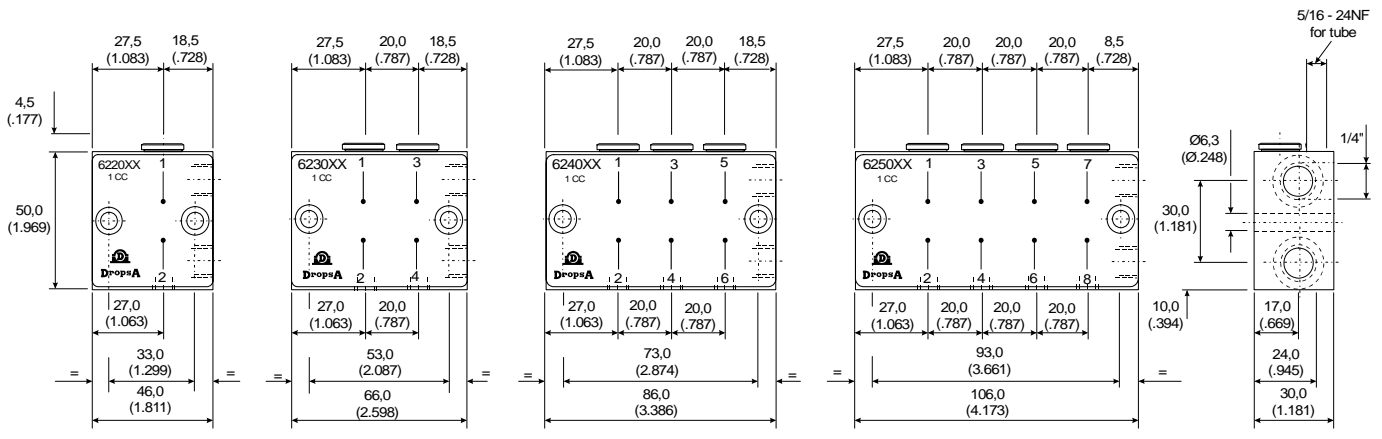

DROPSA STANDARD - DIN 3852 Ø mm				
Plug	Ø Tube	Nut	Ring	Fitting
926001	6	91396	91590	92337
	8	91402	91596	92266
	10	91406	91601	92242
NPTF DRY SEAL Ø INCHES				
850281	1/4	850200	850220	850250
	5/16	850201	850221	850252
	3/8	850202	850222	850254

DROPSA STANDARD - Ø mm			
Cone	Bush	Ø Tube	Plug
93004	92004	4	91005
NPTF DRY SEAL Ø INCHES			
93004	92026	Ø 5/32	91005

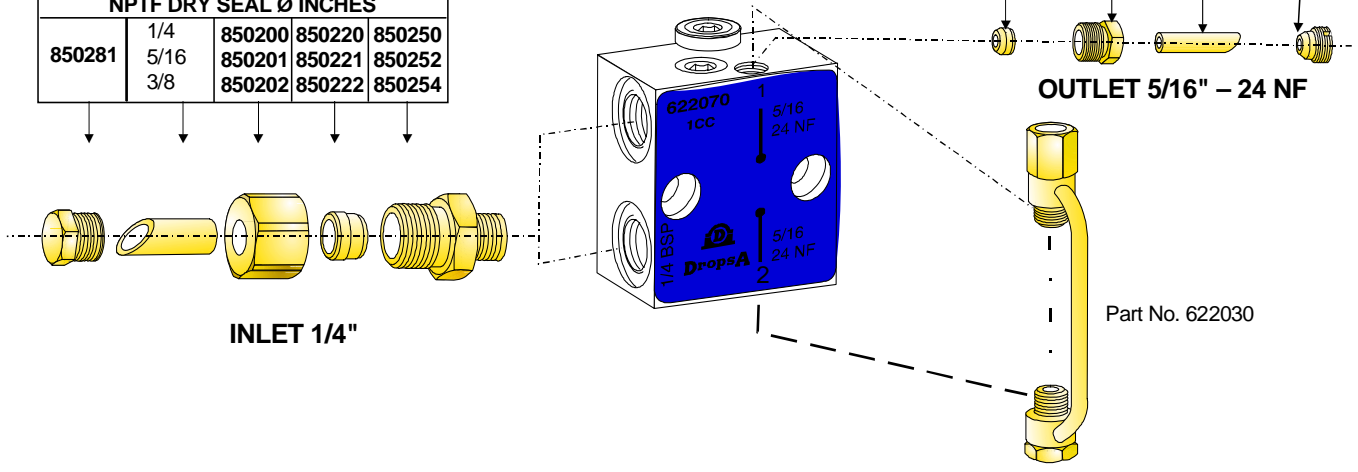

INLET 1/4"

OUTLET 5/16" - 24 NF

Part No. 622030

The fixing parts which are indicated thus * are to be ordered separately.

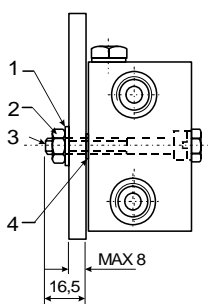

Pos	Part No.	Qty.	Description	
*1	16009	2	Spring washer	Metric
*2	16335	2	Nut M6	
*3	12534	2	Screw M6 x 45	
4	622017	2	Bushing	
*1	16012	2	Spring washer	Inches
*2	16499	2	Nut 1/4-28 UNF Hex. 7/16	
*3	12562	2	Screw 1/4-28 UNF x 1 3/4	
4	622017	2	Bushing	

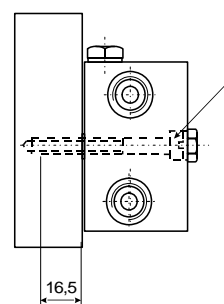

WELD PLATES FOR FEEDERS

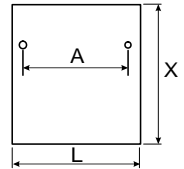

N.	Part No.	DIMENSIONS (INCHES)		
		A	L	X
1	111585	33 (1.29)	45 (1.77)	120 (4.72)
2	111586	53 (2.08)	65 (2.55)	120 (4.72)
3	111587	73 (2.87)	85 (3.34)	120 (4.72)
4	111588	93 (3.66)	105 (4.13)	120 (4.72)



PROXIMITY SWITCH FOR FLOW CONTROL

1655162
 1655163
 1655166

ENGLISH

1. DESCRIPTION

This proximity switch has been designed for controlling feeder blocks of the Dual line system.

It is particularly suitable for controlling the correct lubrication of very important friction points.

In order to obtain a correct movement of the piston in both directions you must install a proximity switch on the adjusting turret and another on the opposite side.

2. HOW TO ORDER

TURRET SIDE	
<i>Sensor-ass.y</i>	<i>for feeder</i>
1655162	DMM
1655166	DM – AG6 – AP6

SIDE OPPOSITE THE TURRET	
<i>Sensor-ass.y</i>	<i>for feeder</i>
1655163	DMM - DM



Sensor assembly turret-side

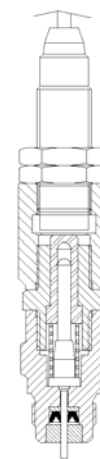

Sensor assembly on side opposite the turret

3. TECHNICAL FEATURES

- Working pressure = 200 bar
- Max. output current = 200 mA
- Supply Voltage = 10 ÷ 30 V d.c.
- Current consumption at 24 V d.c. = <18 mA
- Outputs = PNP – N.O.
- Protection type = IP 67
- Temperature range = -25°C +70°C

3. SPARE PARTS

Sensor code 1523812

WARNING:..the correct movement of a metering piston guarantees that only the controlled feeder block is working, but it does not guarantee that feeders on other dual line blocks, are working too.For this reason it is necessary to install a micro switch on each feeder block which needs monitoring.





FEEDER BLOCK SERIES AP6

Adjustable Discharge.25-1.5 cc.per/stroke
(.15 -.091 cu. in./stroke)
Dual Line System

622250 623250
624250 625250
622150 623150
624150 625150
622175 623175
624175 625175

ENGLISH

PRODUCT DATA SHEET

DESCRIPTION:

The feeder body is made of special anti-friction steel. Pistons are made of tempered steel. Bores and pistons are lapped to provide superior sealing. The indicator turrets are provided with integral adjusting screws together with a metacrylate cover and seal. On request an aluminium cover can be supplied. The feeder body has a galvanized finish and features an adaptor for single or double outlet conversion.

SPECIFICATION:

Temperature range: -30 to +80°C.
Max. pressure (inlet): 400 bar (5800 psi.)
Cycles: 100/min.
Min. Viscosity: 100 cSt (462 SSU)
Grease Max.: 265 ASTM (NLGI 2)*
Connections:
Inlet: 1/4"
Outlet: 1/4"

(*) For different type of grease please contact your supplier

ORDERING INFORMATION:

Ordering is by Part No., refer to the following table:

Thread.	Part No.	Weight.		No. Outlets.
		Kg.	Lbs.	
Dropsa Standard BSP.	622250	0,850	1.87	1-2
	623250	1,300	2.87	2-4
	624250	1,660	3.65	3-6
	625250	2,050	4.51	4-8
Din 3852 X BSP	622150	0,850	1.87	1-2
	623150	1,300	2.87	2-4
	624150	1,660	3.65	3-6
	625150	2,050	4.51	4-8
NPTF	622175	0,850	1.87	1-2
	623175	1,300	2.87	2-4
	624175	1,660	3.65	3-6
	625175	2,050	4.51	4-8

INSTALLATION/OPERATION:

Function: (Refer to Figs. 1 and 3.)The feeder discharge is controlled by a servo-piston (A) and metering piston (B)

and can be arranged to provide a single or double outlet. Fig. D-E= 2 separate outlets Fig. F-G=1outlet. Feeders are normally supplied with double outlets unless otherwise specified. Retrospective conversion can be undertaken by fitting adaptor Y (code 622076) for single outlet and X (code 622077) for double outlet (see



following page). When single outlet feeders are used the discharge per complete cycle = .5-3 cc/stroke (.03-.183 cu.in./stroke).

Dimensions: (Refer to Fig. 2.)

Mounting: (Refer to Fig. 2.) Aluminium bushings Part. No 3008107 are supplied for mounting on uneven surfaces to prevent distortion or damage due to overtightening.

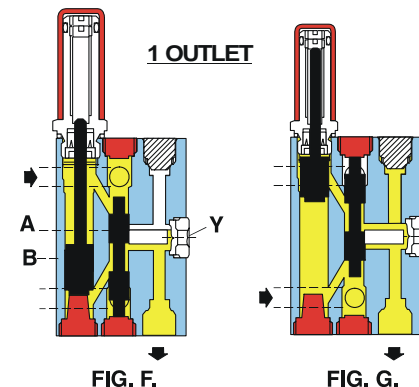
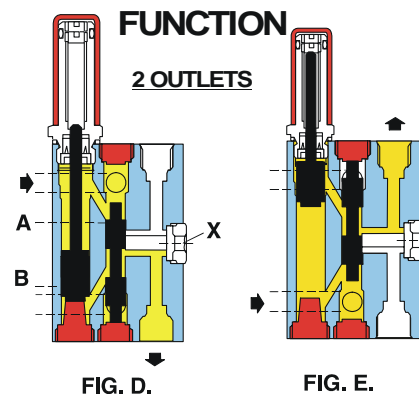

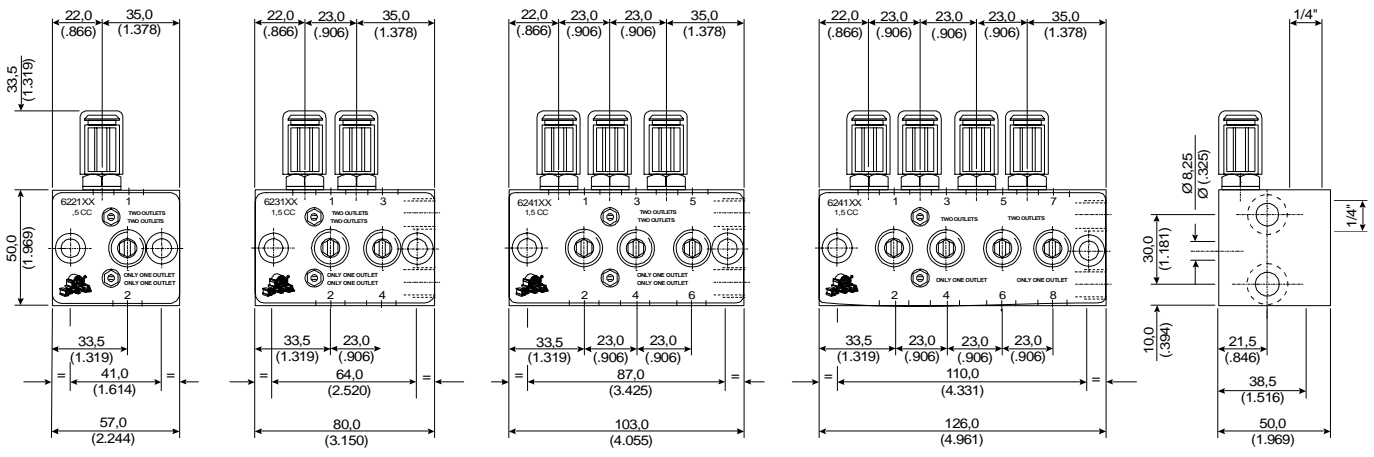

Dropsa Standard feeder blocks are normally supplied with outlets having a conical seating for Ø8 mm. (5/16") tube. This is simple and cost effective as no fitting is required.

If required a check-valve Part No. 92313 BSP or Part No. 92340 NPTF can be fitted at the outlet. Order separately.

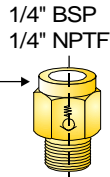

Aluminium cover (optional) Part No. 622256
Metacrylate cover Part No. 622160

DROPSA STANDARD				
Reducer	Cone	Nut	Ø Tube	Plug
671038	93006	92014	Ø 6	91011
671038	93008	92053	Ø 8	91011

Seal Part No. 671001

INLET 1/4"

OUTLET 1/4"

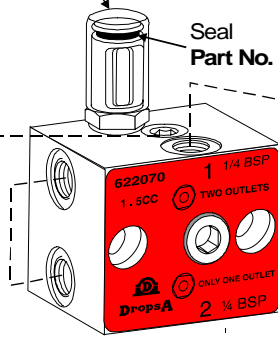
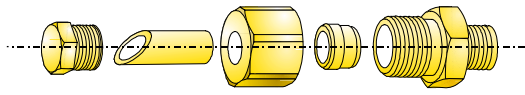

DROPSA STANDARD DIN 3852 BSP Ø mm.				
Plug	Tube Ø	Nut	Ring	Fitting
926001	Ø 8	91402	91596	92266
	Ø 10	91406	91601	92242
	Ø 12	91411	91607	92198
NPTF DRY SEAL Ø INCHES				
850281	Ø 5/16	850201	850221	850252
	Ø 3/8	850202	850222	850254
	Ø 1/2	850203	850223	850256

DIN 3852 BSP Ø mm				
Fitting	Ring	Nut	Ø Tube	Plug
91952	91590	91396	Ø 6	622167
91959	91596	91401	Ø 8	
91966	91601	91406	Ø 10	
NPTF DRY SEAL Ø INCHES				
850250	850220	850200	Ø 1/4	850281
850252	850221	850201	Ø 5/16	
850254	850222	850202	Ø 3/8	

- The double outlet adaptor (622077) is identifiable by two parallel line markings in the centre; the single outlet adaptor (622076) has a circular marking only.

WELD PLATES FOR FEEDERS

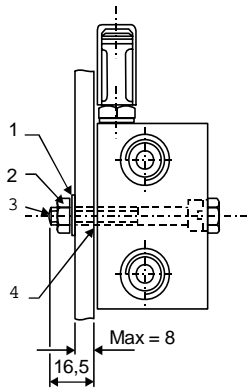

The fixing parts which are indicated are to be ordered

Pos.	Part No.	Qty.	Description	
• 1	16012	2	Spring washer	Metric
• 2	16406	2	Nut M8 - Hex	
• 3	12552	2	Screw M8 x 60	
• 4	3008107	2	Bushing	
• 1	16012	2	Spring washer	Inch
• 2	16500	2	Nut 5/16-24 UNF x 2-1/2	
• 3	12561	2	Screw 5/16-24 UNF x 2-1/2	
• 4	3008107	2	Bushing	

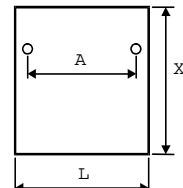
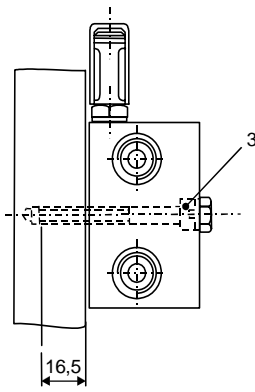

Pos.	Part No.	Dimensions (inches)		
		A	L	X
1	111581	41 (1.614")	60 (2.362")	140 (5.511")
2	111582	64 (2.520")	85 (3.346")	140 (5.511")
3	111583	87 (3.425")	110 (4.330")	140 (5.511")
4	111584	110 (4.330")	130 (5.118")	140 (5.511")



FEEDER BLOCK SERIES AP6F

Fixed Discharge 1,5cc. per stroke
(.091 cu.in./stroke)
Dual Line System

622190 623190
624190 625190
622180 623180
624180 625180
622140 623140
624140 625140

ENGLISH

PRODUCT DATA SHEET

DESCRIPTION:

The feeder body is made of special anti-friction steel. Pistons are made of tempered steel. Bores and pistons are lapped to provide superior sealing. These feeders do not employ indicator turrets (see AP6 series) and are used for special applications. The body has a galvanized finish and features an adaptor for single or double outlet conversion. They are set by the factory at 1,5 cc./stroke(.091 cu. in./ stroke) unless otherwise requested.

SPECIFICATION:

Temperature range: -30 +80°C.(-22+176°F.)
Max. pressure (inlet): 400 bar (5800 psi.)
Cycles: 100/min.
Min. Viscosity: 100 cSt (462 SSU)
Grease Max.: 265 ASTM (NLGI 2)*
Connections:
Inlet: 1/4"
Outlet: 1/4"

(*) For different type of grease please contact your supplier

ORDERING INFORMATION:

Ordering is by Part No., refer to the following table:

Thread	Part No.	Weight.		No. outlets
		Kg.	Lbs.	
Dropsa Standard BSP	622180	0,820	1.80	1 - 2
	623180	1,230	2.71	2 - 4
	624180	1,560	3.44	3 - 6
	625180	1,920	4.23	4 - 8
Din 3852 x BSP	622190	0,820	1.80	1 - 2
	623190	1,230	2.71	2 - 4
	624190	1,560	3.44	3 - 6
	625190	1,920	4.23	4 - 8
NPTF	622140	0,820	1.80	1 - 2
	623140	1,230	2.71	2 - 4
	624140	1,560	3.44	3 - 6
	625140	1,920	4.23	4 - 8

INSTALLATION/OPERATION:

Function:(Refer to Figs. 1 and 3.)

In installations where backpressure is detected at the outlets of the feeder blocks, a check- valve must be fitted to each outlet. The feeder discharge is controlled by a servo-piston (A) and metering piston (B) and can be arranged to provide a single or double outlet. Fig. D-E= 2 separate outlets Fig. F-G =1 outlet. Feeders are normally supplied with double outlets unless otherwise specified. Retrospective conversion can be undertaken by fitting adaptor Y (Part No. 622076) for single outlet and X (Part No. 622077) for double outlet. When single



outlet feeders are used the discharge per complete cycle = 3 cc./stroke (.183 cu.in. / stroke).

Dimensions:

Mounting: (Refer to Fig. 2.)

Aluminium bushings (Part. No. 3008107) are supplied for mounting on uneven surfaces to prevent distortion or damage due to overtightening.

FUNCTION

2 OUTLETS

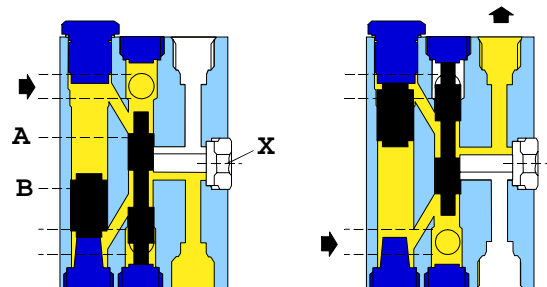

FIG. D.

FIG. E.

1 OUTLET

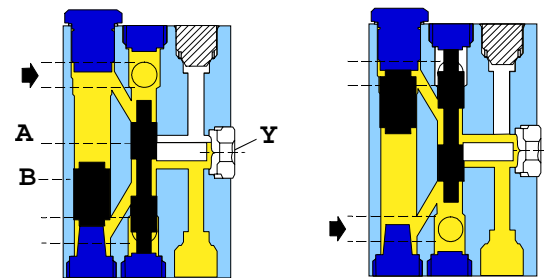
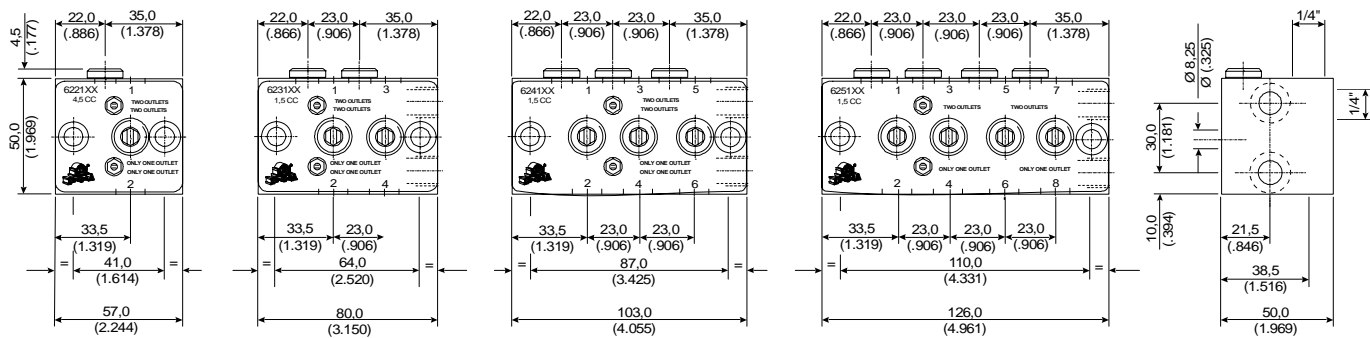

FIG. F.

FIG. G.



Dropsa Standard feeder blocks are normally supplied with outlets having a conical seating for Ø8 mm. (5/16") tube. This is simple and cost effective as no fitting is required.

If required a check-valve Part No. 92313 BSP or Part No. 92340 NPTF can be fitted at the outlet. Order separately.

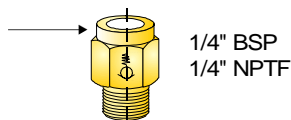

DROPSA STANDARD				
Reducer	Cone	Nut	Ø Tube	Plug
671038	93006	92014	Ø 6	91011
	93008	92053	Ø 8	91011

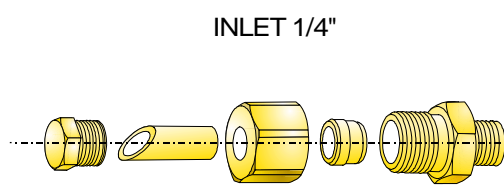

INLET 1/4"

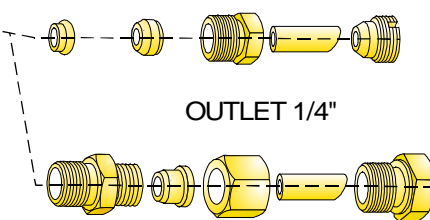
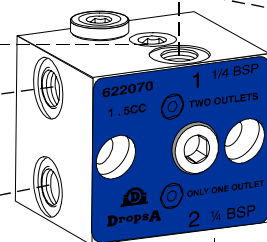

OUTLET 1/4"

DROPSA STANDARD DIN 3852 BSP Ø mm.				
Plug	Tube Ø	Nut	Ring	Fitting
926001	Ø 8	91402	91596	92266
	Ø 10	91406	91601	92242
	Ø 12	91411	91607	92198
NPTF DRY SEAL Ø INCHES				
850281	Ø 5/16	850201	850221	850252
	Ø 3/8	850202	850222	850254
	Ø 1/2	850203	850223	850256

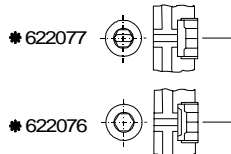

DIN 3852 BSP Ø mm				
Fitting	Ring	Nut	Ø Tube	Plug
91952	91590	91396	Ø 6	622167
91959	91596	91401	Ø 8	
91966	91601	91406	Ø 10	
NPTF DRY SEAL Ø INCHES				
850250	850220	850200	Ø 1/4	850281
850252	850221	850201	Ø 5/16	
850254	850222	850202	Ø 3/8	

- The double outlet adaptor (622077) is identifiable by two parallel line markings in the centre; the single outlet adaptor (622076) has a circular marking only.

The fixing parts which are indicated thus * are to be ordered separately.

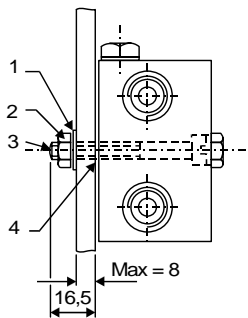

Pos.	Part No.	Qty.	Description	
• 1	16012	2	Spring washer	Metric
• 2	16406	2	Nut M8 - Hex	
• 3	12552	2	Screw M8 x 60	
• 4	3008107	2	Bushing	
• 1	16012	2	Spring washer	Inch
• 2	16500	2	Nut 5/16-24 UNF x 2-1/2	
• 3	12561	2	Screw 5/16-24 UNF x 2-1/2	
• 4	3008107	2	Bushing	

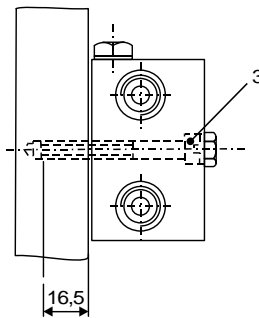

WELD PLATES FOR FEEDERS

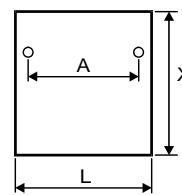

Pos.	Part No.	Dimensions (inches)		
		A	L	X
1	111581	41 (1.614")	60 (2.362")	140 (5.511")
2	111582	64 (2.520")	85 (3.346")	140 (5.511")
3	111583	87 (3.425")	110 (4.330")	140 (5.511")
4	111584	110 (4.330")	130 (5.118")	140 (5.511")



FEEDER BLOCK SERIES AG6

Adjustable Discharge 0,25 - 3 cc. per/stroke
(.015-.183 cu. in. / stroke)
Dual Line System

671200 671300
671310 672300
672200 672310
673300 673200
673310 673400
674200 674310

ENGLISH

PRODUCT DATA SHEET

DESCRIPTION:

The feeder body is made of special anti-friction steel. Pistons are made of tempered steel. Bores and pistons are lapped to provide superior sealing. The indicator turrets are provided with integral adjusting screws together with a metacrylate cover and seal. On request an aluminium cover can be supplied. The feeder body has a galvanised finish and features an adaptor for single or double outlet conversion.

SPECIFICATION:

Temperature range: -30 to +80°C.
Max. pressure (inlet): 400 bar (5800 psi.)
Cycles: 100/min.
Min. Viscosity: 100 cSt (462 SSU)
Grease Max.: 265 ASTM (NLGI 2)*
Connections:
Inlet: 3/8"
Outlet: 1/4"

(*) For different type of grease please contact your supplier

In installations where backpressure is detected at the outlets of the feeder blocks, a checkvalve must be fitted to each outlet (see following page).

ORDERING INFORMATION:

Ordering is by Part No., refer to the following table:

Thread.	Part No.	Weight.		No. Outlets.
		Kg.	Lbs.	
Dropsa Standard BSP	671300	1,600	3.52	1
	672300	2,250	4.95	2
	673300	2,950	6.49	3
	674300	3,550	7.81	4
Din 3852 x BSP	671200	1,600	3.52	1
	672200	2,250	4.95	2
	673200	2,950	6.49	3
	674200	3,550	7.81	4
NPTF	671310	1,600	3.52	1
	672310	2,250	4.95	2
	673310	2,950	6.49	3
	674310	3,550	7.81	4

Function:(Refer to Figs. 1 and 3.) The feeder discharge is controlled by a servo -piston (A) and a metering piston (B) and can be arranged to provide a single or double outlet. Fig. D-E = 2 separate outlets Fig. F-G=1 outlet. Feeders are normally supplied with double outlets unless otherwise specified. Retrospective conversion can be undertaken by fitting adaptor Y (Part No. 622076) for single outlet and X (Part No. 622077) for double outlet (see following page). When single outlet feeders are used the discharge per complete cycle = 0,5-6 cc./stroke.(.03 - .366 cu. in./stroke)



The double outlet adaptor (Part No. 622077) is identifiable by two parallel line markings in the centre; the single outlet adaptor (Part No.622076) has a circular marking only.

Dimensions:

Mounting: (Refer to Fig. 2.)

Aluminium bushings (Part No. 3008107) are supplied

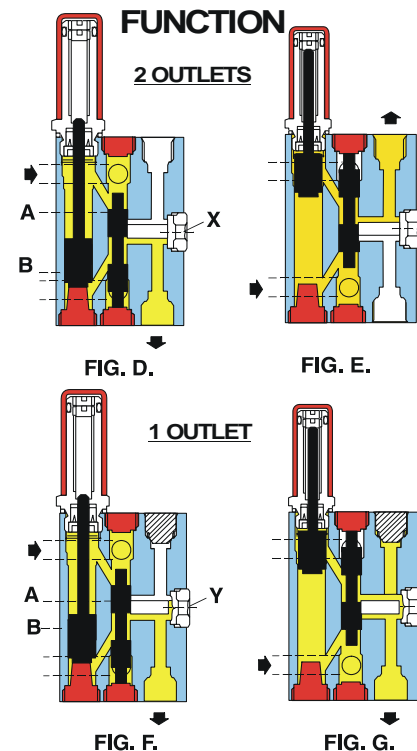

for mounting on uneven surfaces to prevent distortion or

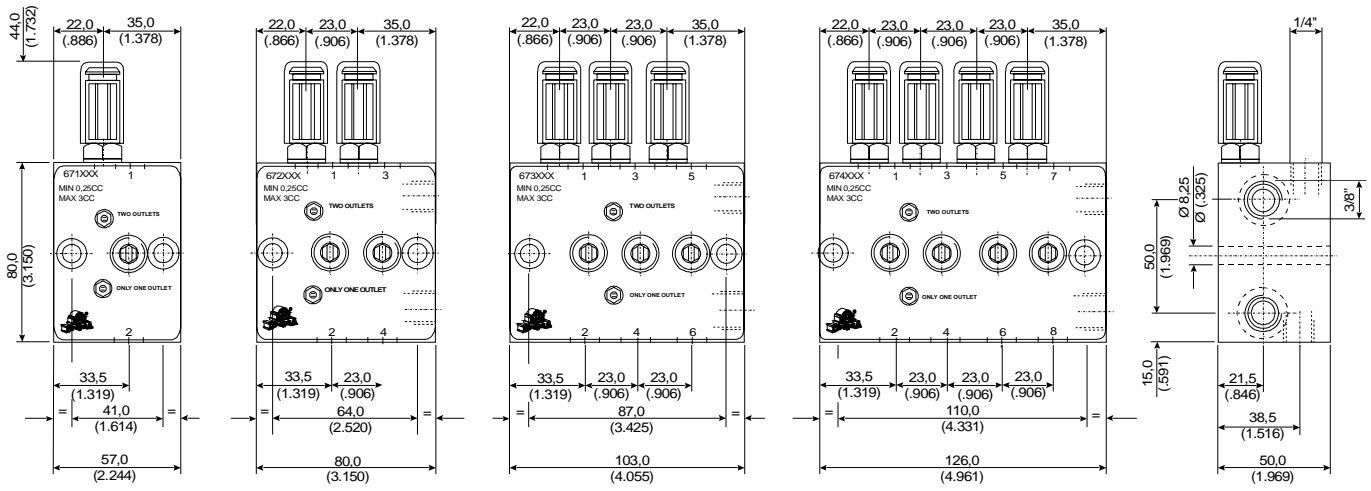

Dropsa Standard feeder blocks are normally supplied with outlets having a conical seating for Ø8 mm. (5/16") tube. This is simple and cost effective as no fitting is required.

If required a check-valve Part No. 92313 BSP or Part No. 92340 NPTF can be fitted at the outlet. Order separately.

1/4" BSP
1/4" NPTF

Aluminium cover (optional)
Part No. 618215
Metacrylate cover
Part No. 671028

DROPSA STANDARD				
Reducer	Cone	Bush	Ø Tube	Plug
671038	93006 93008	92014 92053	Ø 6 Ø 8	91011 91011

Seal
Part No. 671001

INLET 3/8"

OUTLET 1/4"

DROPSA STANDARD DIN 3852 BSP Ø mm.				
Plug	Tube Ø	Nut	Ring	Fitting
926002	Ø 10	91406	91601	92269
	Ø 12	91411	91607	92240
	Ø 16	91416	91612	92241
NPTF DRY SEAL Ø INCHES				
850282	Ø 3/8	850202	850222	850255
	Ø 1/2	850203	850223	850257
	Ø 5/8	850204	850224	850259

DIN 3852 BSP Ø mm				
Fitting	Ring	Nut	Ø Tube	Plug
91952	91590	91396	Ø 6	622167
91959	91596	91401	Ø 8	
91966	91601	91406	Ø 10	
NPTF DRY SEAL Ø INCHES				
850250	850220	850200	Ø 1/4	850281
850252	850221	850201	Ø 5/16	
850254	850222	850202	Ø 3/8	

- The double outlet adaptor (622077) is identifiable by two parallel line markings in the center; the single outlet adaptor (622076) has a circular marking only.

WELD PLATES FOR FEEDERS

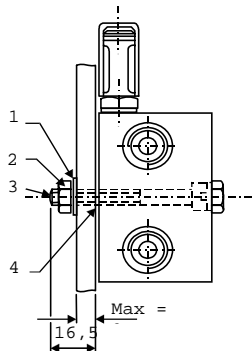

The fixing parts which are to be ordered

Pos.	Part	Qty	Descripti	
• 1	16012	2	Spring	Metric
• 2	16406	2	Nut M8 -	
• 3	12552	2	Screw M8 x 60	
• 4	3008107	2	Bushing	
• 1	16012	2	Spring	Inch
• 2	16500	2	Nut 5/16-24 UNF x 2-	
• 3	12561	2	Screw 5/16-24 UNF x 2-	
• 4	3008107	2	Bushing (3 - 3/4)	

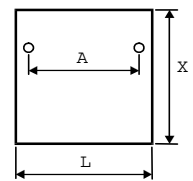
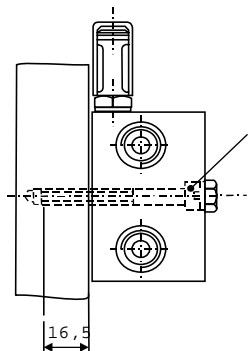

Pos	Part	Dimensions		
		A	L	X
1	111581	41 (1.614)	60 (2.362)	140 (5.511)
2	111582	64 (2.520)	85 (3.346)	140 (5.511)
3	111583	87 (3.425)	110 (4.330)	140 (5.511)
4	111584	110 (4.330)	130 (5.118)	140 (5.511)



FEEDER BLOCK SERIES AG 6F

Fixed discharge 3 cc. per stroke
(.183 cu. in./stroke) Dual Line System

671190 672190
673190 674190
671180 672180
673180 674180
671140 672140
673140 674140

PRODUCT DATA SHEET

ENGLISH

DESCRIPTION:

The feeder body is made of special anti-friction steel. Pistons are made of tempered steel. Bores and pistons are lapped to provide superior sealing. These feeders do not employ indicator turrets (see AG6 series) and are used for special applications. The body has a galvanized finish and features an adaptor for single or double outlet conversion. They are set by the factory at 3 cc. (.183 cu. in.) unless otherwise requested.

SPECIFICATION:

- Temperature range: -30 to +80°C.
- Max. pressure (inlet): 400 bar (5800 psi.)
- Max. Cycles: 100/min.
- Min. Viscosity: 100 cSt (462 SSU)
- Grease Max.: 265 ASTM (NLGI 2)*

(*) For different type of grease please contact your supplier

Connections

- Inlet: 3/8"
- Outlet: 1/4"

ORDERING INFORMATION:

Ordering is by Part No., refer to the following table:

Thread	Part No.	Weight.		No. Outlets.
		Kg.	Lbs.	
Dropsa Standard BSP	671180	1,560	3.43	1-2
	672180	2,160	4.76	2-4
	673180	2,820	6.21	3-6
	674180	3,370	7.42	4-8
Din 3852 X BSP	671190	1,560	3.43	1-2
	672190	2,160	4.76	2-4
	673190	2,820	6.21	3-6
	674190	3,370	7.42	4-8
NPTF	671140	1,560	3.43	1-2
	672140	2,160	4.76	2-4
	673140	2,820	6.21	3-6
	674140	3,370	7.42	4-8

INSTALLATION/OPERATION:

Function:(Refer to Figs. 1 and 3.)The feeder discharge is controlled by a servo-piston (A)and a metering piston (B) and can be arranged to provide a single or double outlet. Fig. D-E = 2 separate outlets Fig. F-G. = 1 outlet. Feeders are normally supplied with double outlets unless otherwise specified. Retrospective conversion can be undertaken by fitting adaptor Y (Part No. 622076) for single outlet and X (Part No. 622077) for double outlet (see following page). When single outlet feeders are used the discharge per complete cycle = 6 cc./stroke (.366 cu. in./stroke).

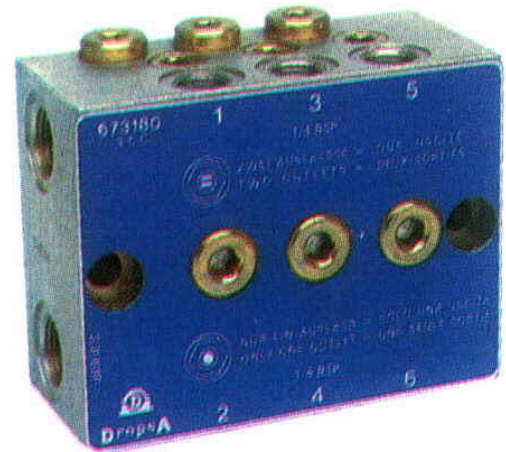

Dimensions: (Refer to Fig. 2.).

Mounting: (Refer to Fig. 2.). Aluminium bushings (Part No. 3008107) are supplied for mounting on uneven surfaces to prevent distortion or damage due to overtightening.

FUNCTION

2 OUTLETS

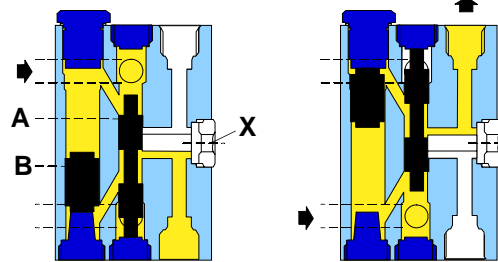

FIG. D.

FIG. E.

1 OUTLET

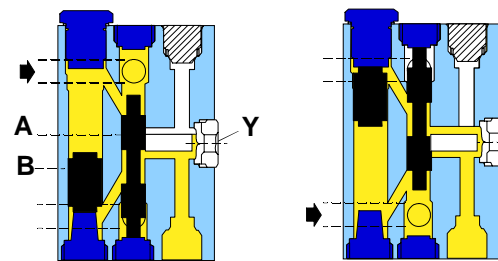
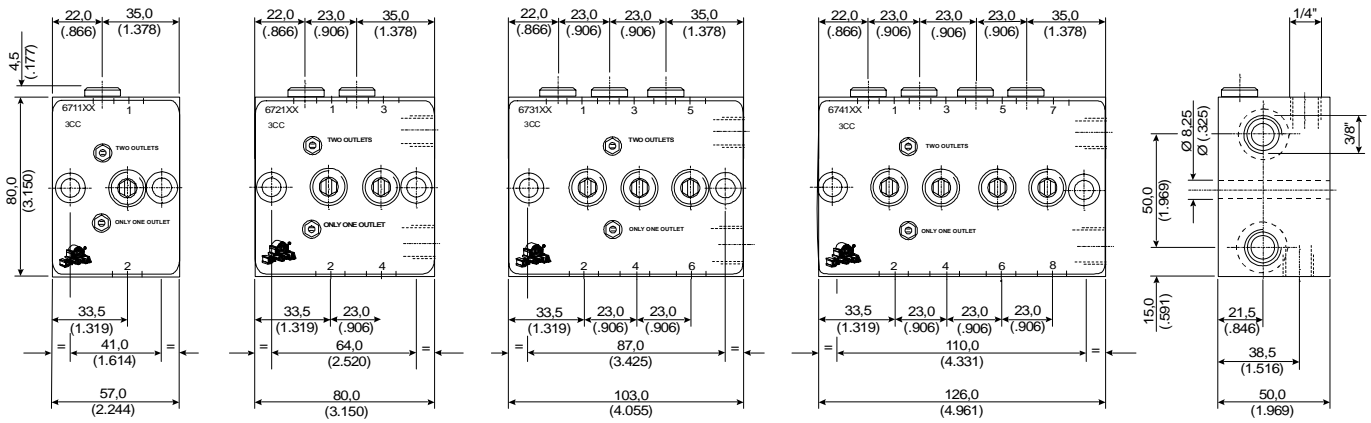

FIG. F.

FIG. G.



Dropsa Standard feeder blocks are normally supplied with outlets having a conical seating for Ø8 mm. (5/16") tube.
This is simple and cost effective as no fitting is required.

DROPSA STANDARD				
Reducer	Cone	Bush	Ø Tube	Plug
671038	93006	92014	Ø 6	91011
	93008	92053	Ø 8	91011

If required a check-valve
Part No. 92313 BSP or
Part No. 92340 NPTF
can be fitted at the
outlet. Order separately.

1/4" BSP
1/4" NPTF

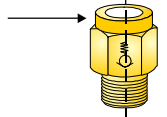

INLET 3/8"

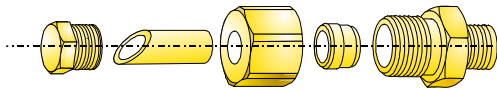

DROPSA STANDARD DIN 3852 BSP Ø mm.				
Plug	Tube Ø	Nut	Ring	Fitting
926002	Ø 8	91406	91601	92269
	Ø 10	91411	91607	92240
	Ø 12	91416	91612	92241
NPTF DRY SEAL Ø INCHES				
850282	Ø 5/16	850202	850222	850255
	Ø 3/8	850203	850223	850257
	Ø 1/2	850204	850224	850259

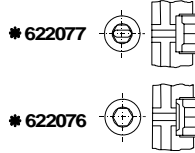

OUTLET 1/4"

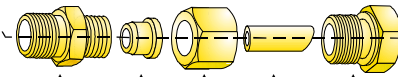

DIN 3852 BSP Ø mm				
Fitting	Ring	Nut	Ø Tube	Plug
91952	91590	91396	Ø 6	622167
91959	91596	91401	Ø 8	
91966	91601	91406	Ø 10	
NPTF DRY SEAL Ø INCHES				
850250	850220	850200	Ø 1/4	850281
850252	850221	850201	Ø 5/16	
850254	850222	850202	Ø 3/8	

- The double outlet adaptor (**622077**) is identifiable by two parallel line markings in the centre;
the single outlet adaptor (**622076**) has a circular marking only.

WELD PLATES FOR FEEDERS

The fixing parts which are indicated thus *
are to be ordered separately.

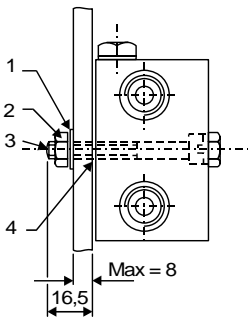

Pos.	Part No.	Qty.	Description	
• 1	16012	2	Spring washer	Metric
• 2	16406	2	Nut M8 - Hex	
• 3	12552	2	Screw M8 x 60	
• 4	3008107	2	Bushing	
• 1	16012	2	Spring washer	Inch
• 2	16500	2	Nut 5/16-24 UNF x 2-1/2	
• 3	12561	2	Screw 5/16-24 UNF x 2-1/2	
• 4	3008107	2	Bushing	

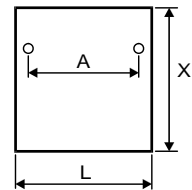
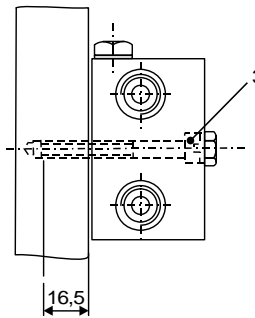

Pos.	Part No.	Dimensions (inches)		
		A	L	X
1	111581	41 (1.614")	60 (2.362")	140 (5.511")
2	111582	64 (2.520")	85 (3.346")	140 (5.511")
3	111583	87 (3.425")	110 (4.330")	140 (5.511")
4	111584	110 (4.330")	130 (5.118")	140 (5.511")



FEEDER BLOCK SERIES AGG6

Adjustable discharge 1.5 -12 cc. per stroke
(.091 - .732 cu. in./ stroke) Dual Line System

626200 627200
628200 629200
626230 627230
628230

ENGLISH

PRODUCT DATA SHEET

DESCRIPTION:

The feeder body is made of special anti-friction steel. Pistons are made of tempered steel. Bores and pistons are lapped to provide superior sealing. The indicator turrets are provided with integral adjusting screws together with a metacrylate cover and seal. On request an aluminium cover can be supplied. The feeder body has a galvanized finish and features an adaptor for single or double outlet conversion.

SPECIFICATION:

Temperature range: -30 - +80°C.
Max. pressure (inlet): 400 bar (5800 psi.)
Cycles: 100/min.
Min. Viscosity: 100 cSt (462 SSU)
Grease Max.: 265 ASTM (NLGI 2)*

(*) For different type of grease please contact your supplier

Connections:

Inlet: 3/8"
Outlet: 3/8"

ORDERING INFORMATION:

Ordering is by Part No., refer to the following table:

Thread	Part No.	Weight.		No. Outlets.
		Kg.	Lbs.	
Dropsa Standard BSP	626200	4,600	10.12	1 - 2
	627200	6,650	14.63	2 - 4
	628200	9,200	20.24	3 - 6
	629200	11,400	25.08	4 - 8
NPTF	626230	4,600	10.12	1 - 2
	627230	6,650	14.63	2 - 4
	628230	9,200	20.24	3 - 6
	629230	11,400	25.08	4 - 8

INSTALLATION/OPERATION:

Function:(Refer to Figs. 1 and 3.)The feeder discharge is controlled by a servo-piston (A) and metering piston (B) and can be arranged to provide a single or double outlet. Fig. D-E = 2 separate outlets Fig. F-G = 1 outlet. Feeders are normally supplied with double outlets unless otherwise specified. Retrospective conversion can be undertaken by fitting adaptor Y (Part No. 626210) for single outlet and X (Part No.626209) for double outlet (see following page). When single outlet feeders are used the discharge per complete cycle = 3-24 cc./stroke (.183-1.464 cu.in./stroke).

Dimensions: (Refer to Fig. 2.).

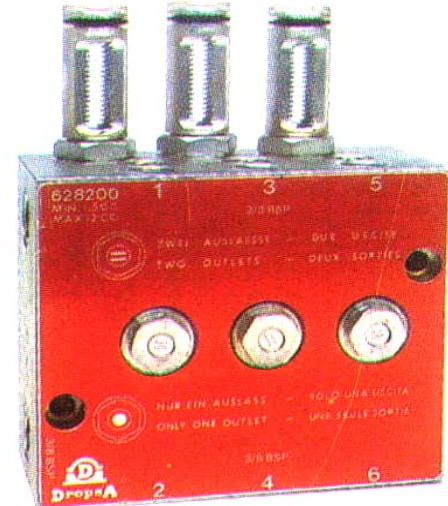

(Part No. 3008107) are supplied for mounting on uneven surfaces to prevent distortion or damage due to overtightening.

FUNCTION

2 OUTLETS

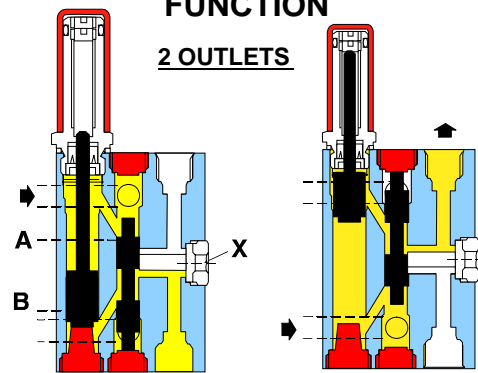

FIG. D.

FIG. E.

1 OUTLET

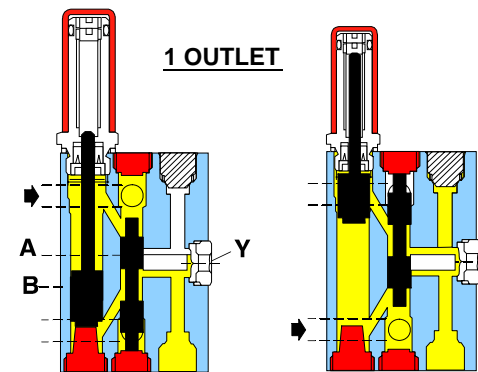
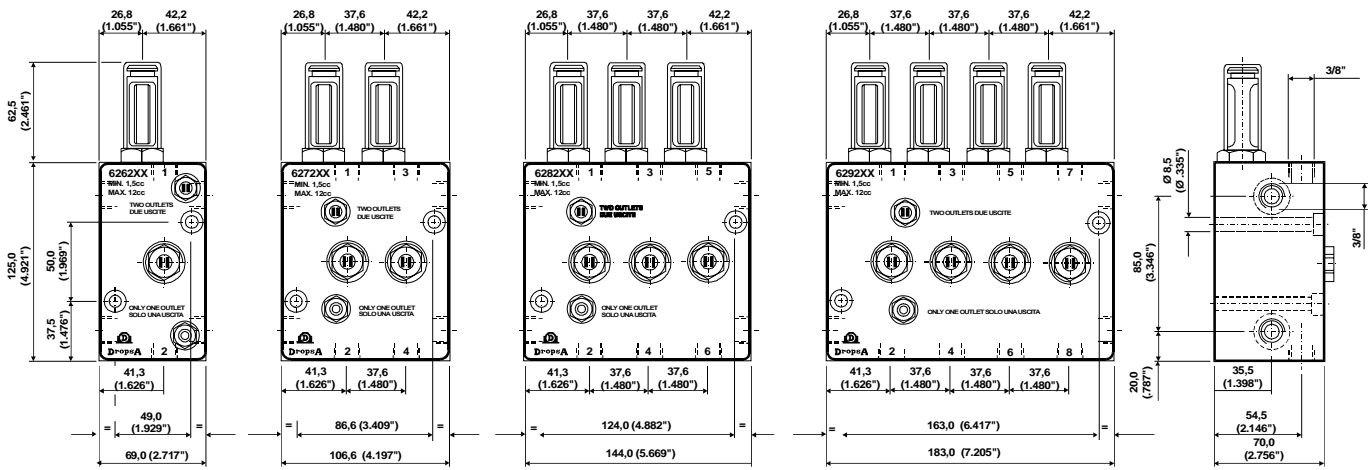

FIG. F.

FIG. G.



Aluminium cover (optional)

Part No. 626021
Metacrylate cover
Part No. 3042118

Dropsa Standard feeder blocks are normally supplied with outlets having a conical seating for Ø10 mm. (3/8") tube.
This is simple and cost effective as no fitting is required.

If required a check-valve
Part No. 92326 BSP or
Part No. 92359 NPTF
can be fitted at the
outlet. Order separately.

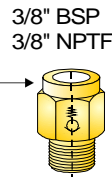

Seal
Part No. 19119

DROPSA STANDARD Ø mm.			
Cone	Bush	Ø Tube	Plug
93010	92010	Ø 10	91003

INLET 3/8"

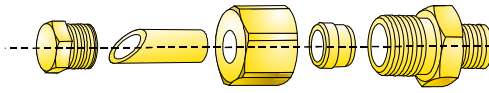

DROPSA STANDARD BSP Ø mm.				
Plug	Tube Ø	Nut	Ring	Fitting
926002	Ø 10	91406	91601	92269
	Ø 12	91411	91607	92240
	Ø 16	91416	91612	92241
NPTF DRY SEAL Ø INCHES				
850282	Ø 3/8	850202	850222	850255
	Ø 1/2	850203	850223	850257
	Ø 5/8	850204	850224	850259

* 626209

* 626210

OUTLET 3/8"

NPTF DRY SEAL Ø INCHES			
		Ø 5/16	
850253	850221	850201	850282
850255	850222	850202	
850257	850223	850203	

*The double outlet adaptor (626209) is identifiable by two parallel line markings in the centre;
the single outlet adaptor (626210) has a circular marking only.

WELD PLATES FOR FEEDERS

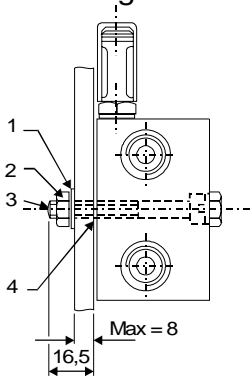

The fixing parts which are indicated thus * are to be ordered separately.

Pos.	Part No.	Qty.	Description	
• 1	16012	2	Spring washer	Metric
• 2	16406	2	Nut M8 - Hex	
• 3	12556	2	Screw M8 x 80	
4	3008107	2	Bushing	
• 1	16012	2	Spring washer	Inch
• 2	16500	2	Nut 5/16-24 UNF	
• 3	12560	2	Screw 5/16-24 UNF x 3-1/4	
4	3008107	2	Bushing	

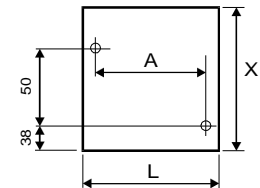
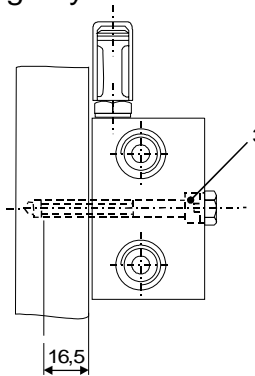

Pos.	Part No.	Dimensions (inches)		
		A	L	X
1	111576	49 (1.929")	70 (2.755")	190 (7.480")
2	111577	86 (3.385")	110 (4.330")	190 (7.480")
3	111578	124 (4.881")	150 (5.905")	190 (7.480")
4	111579	163 (6.417")	183 (7.204")	190 (7.480")



FEEDER BLOCK SERIES AGG6F

Fixed Discharge 12 cc. per/stroke
(.732 cu. in./stroke) Dual Line System

626180 627180
628180 629180
626140 627140
628140 629140

ENGLISH

PRODUCT DATA SHEET

DESCRIPTION:

The feeder body is made of special anti-friction steel. Pistons are made of tempered steel. Bores and pistons are lapped to provide superior sealing. These feeders do not employ indicator turrets (see AGG6 series) and are used for special applications. The body has a galvanized finish and features an adaptor for single or double outlet conversion. They are set by the factory at 12 cc./stroke (.732 cu. in./stroke) unless otherwise requested.

SPECIFICATION:

- Temperature range:** -30 - +80°C.
- Max. pressure (inlet):** 400 bar (5800 psi.)
- Cycles:** 100/min.
- Min. Viscosity:** 100 cSt (462 SSU)
- Grease Max.:** 265 ASTM (NLGI 2)*

(*) For different type of grease please contact your supplier

Connections:

- Inlet:** 3/8"
- Outlet:** 3/8"

ORDERING INFORMATION:

Ordering is by Part No., refer to the following table:

Thread.	Part No.	Weight.		No. Outlets.
		Kg.	Lbs.	
Dropsa Standard BSP	626180	4,470	9.83	1-2
	627180	6,390	14.06	2-4
	628180	8,810	19.39	3-6
	629180	10,880	23.94	4-8
NPTF	626140	4,470	9.83	1-2
	627140	6,390	14.06	2-4
	628140	8,810	19.39	3-6
	629140	10,880	23.94	4-8

INSTALLATION/OPERATION:

Function:(Refer to Figs. 1 and 3.)The feeder discharge is controlled by a servo-piston (A) and metering piston (B) and can be arranged to provide a single or double outlet. Fig.D-E = 2 separate outlets Fig. F-G = 1 outlet. Feeders are normally supplied with double outlets unless otherwise specified. Retrospective conversion can be undertaken by fitting adaptor Y (Part No. 626210) for single outlet and X (Part No. 626209) for double outlet (see following page). When single outlet feeders are used the discharge per complete cycle = 24 cc./stroke (1.464 cu. in./stroke.)

Dimensions: (Refer to Fig. 2.).

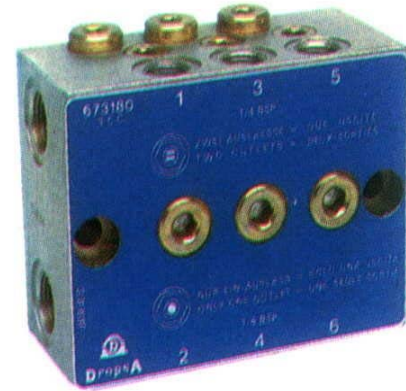

Mounting: (Refer to Fig. 2.)

Aluminium bushings (Part No.3008107) are supplied for mounting on uneven surfaces to prevent distortion or damage due to overtightening

FUNCTION

2 OUTLETS

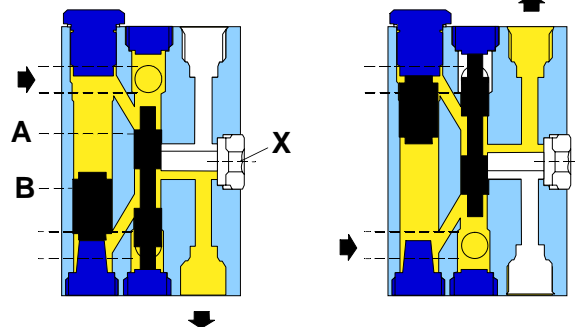

FIG. D.

FIG. E.

1 OUTLET

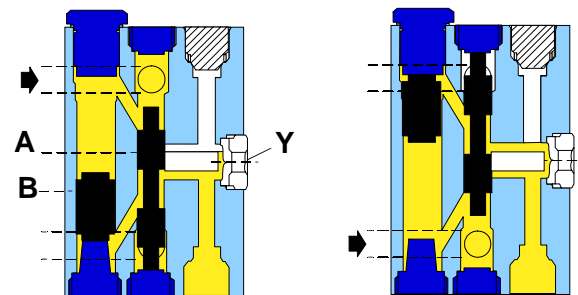
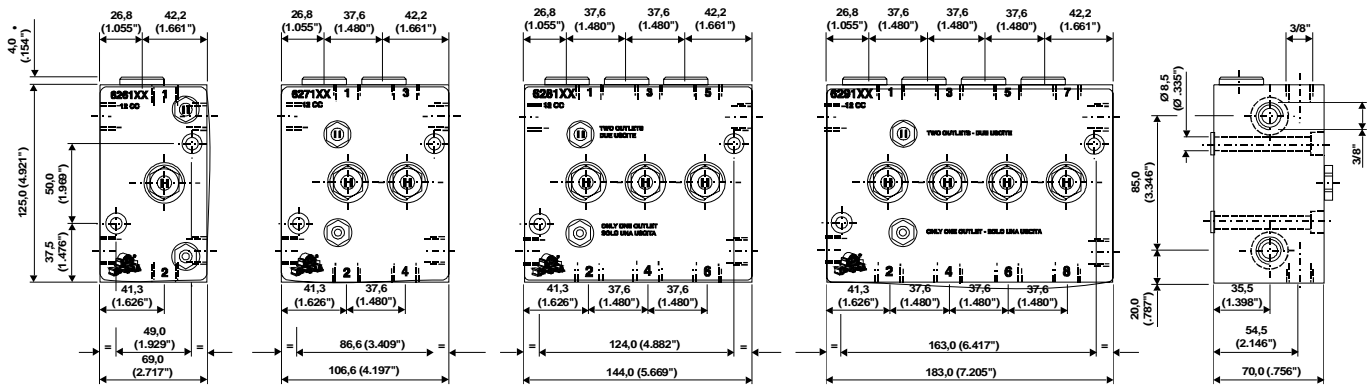

FIG. F.

FIG. G.



Dropsa Standard feeder blocks are normally supplied with outlets having a conical seating for Ø10 mm. (3/8" tube). This is simple and cost effective as no fitting is required.

If required a check-valve Part No. 92326 BSP or Part No. 92359 NPTF can be fitted at the outlet. Order separately.

3/8" BSP
3/8" NPTF

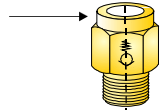

DROPSA STANDARD Ø mm.			
Cone	Bush	Ø Tube	Plug
93010	92010	Ø 10	91003

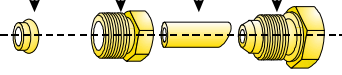

OUTLET 3/8"

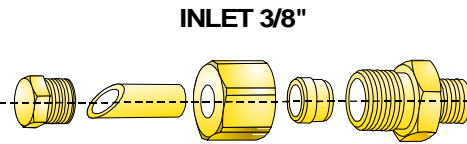

INLET 3/8"

DROPSA STANDARD BSP Ø mm.				
Plug	Tube Ø	Nut	Ring	Fitting
926002	Ø 10	91406	91601	92269
	Ø 12	91411	91607	92240
	Ø 16	91416	91612	92241
NPTF DRY SEAL Ø INCHES				
850282	Ø 3/8	850202	850222	850255
	Ø 1/2	850203	850223	850257
	Ø 5/8	850204	850224	850259

* 626209

* 626210

NPTF DRY SEAL Ø INCHES				
850253	850221	850201	Ø 5/16	
850255	850222	850202	Ø 3/8	850282
850257	850223	850203	Ø 1/2	

*The double outlet adaptor (626209) is identifiable by two parallel line markings in the center; the single outlet adaptor (626210) has a circular marking only.

The fixing parts which are indicated thus • are to be ordered separately.

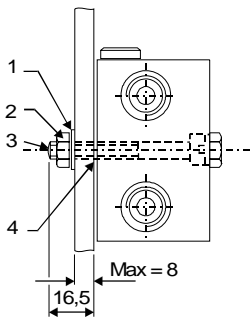

Pos.	Part No.	Qty.	Description	
• 1	16012	2	Spring washer	Metric
• 2	16406	2	Nut M8 - Hex	
• 3	12556	2	Screw M8 x 80	
• 4	3008107	2	Bushing	
• 1	16012	2	Spring washer	Inch
• 2	16500	2	Nut 5/16-24 UNF	
• 3	12560	2	Screw 5/16-24 UNF x 3-1/4	
• 4	3008107	2	Bushing	

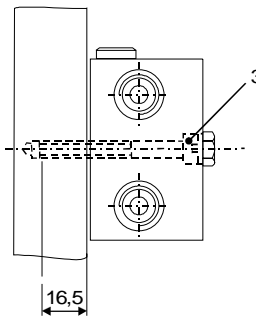

WELD PLATES FOR FEEDERS

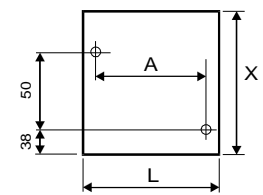

Pos.	Part No.	Dimensions (inches)		
		A	L	X
1	111576	49 (1.929")	70 (2.755")	190 (7.480")
2	111577	86 (3.385")	110 (4.330")	190 (7.480")
3	111578	124 (4.881")	150 (5.905")	190 (7.480")
4	111579	163 (6.417")	183 (7.204")	190 (7.480")



DOUBLE CONTROL METERING VALVES

For Dual Line Lubrication Systems

622200 623200
624200 625200
622260 623260
624260 625260

PRODUCT DATA SHEET

ENGLISH

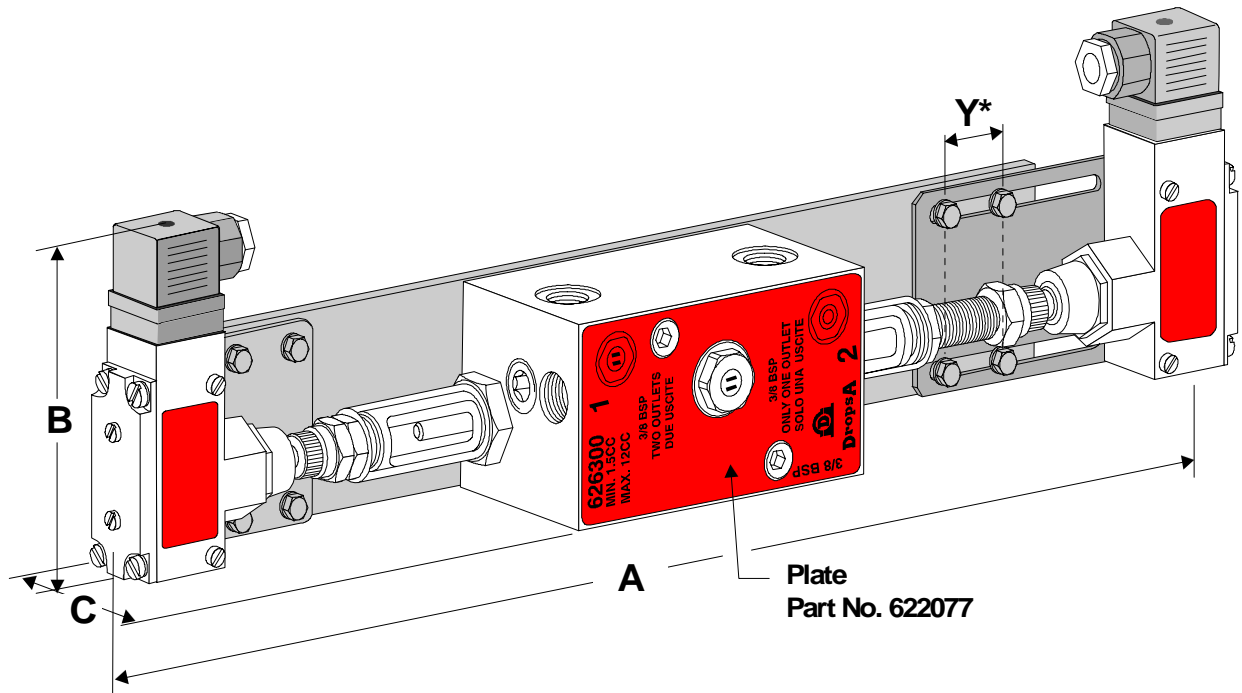

DESCRIPTION:

These units are used especially on heavy machinery. The user can install the valves as required, please note, that the non enclosed version must be mounted in a relatively clean area of the machine. Away from water and dust. The operation of the system becomes extremely reliable and easily controllable by means of these valves. The delivery of the metering valve **Part No. 622300** and **Part No. 671350** can be adjusted varying the length of Y (see the figure) screwing or

unscrewing the regulating nut. The valve can be used either single or double outlet; double outlet is the standard adjustment, to obtain a single outlet valve replace plate **Part No. 622077** (marked with two parallel lines) with plate **Part No. 622076** (marked with a circle) and plug one of the two outlets.

These metering valves are a double controlled version of some of the most commonly used Dual Line metering

SPECIFICATION:

Part No.	Number of outlet	Delivery per outlet		A		B		C	
		cc.	cu.in.	mm.	In.	mm.	In.	mm.	In.
622300	2	.25 -1.5	.015 -.091	350	13.780	80	3.150	70	2.756
671350	2	.25 - 3	.015 -.183	400	15.748	80	3.150	70	2.756
626300	2	12	.732	500	19.685	80	3.150	85	3.346

Type	Code	Adjustment								Delivery variation for each adjustment of Y	
		A max				A min					
		mm.	in.	cc.	cu. in.	mm.	in.	cc.	cu in.	cc.	cu.in.
AP6	622300	20.5	.807	1.5	.091	8.5	.335	,5	.030	,17	.010
AG6	671350	21	.827	3	.183	0	0	,5	.030	,17	.010
AGG6	626300	40	1.575	12	.732	0	0	1,5	.091	,6	.037



POMAC
LUB SERVICES BVBA

Kortrijkstraat 187 B-8770 Ingelmunster

Tel. +32 (0)51 316 205 - Fax +32 (0)51 309 621 info@pomac.be - www.pomac.be

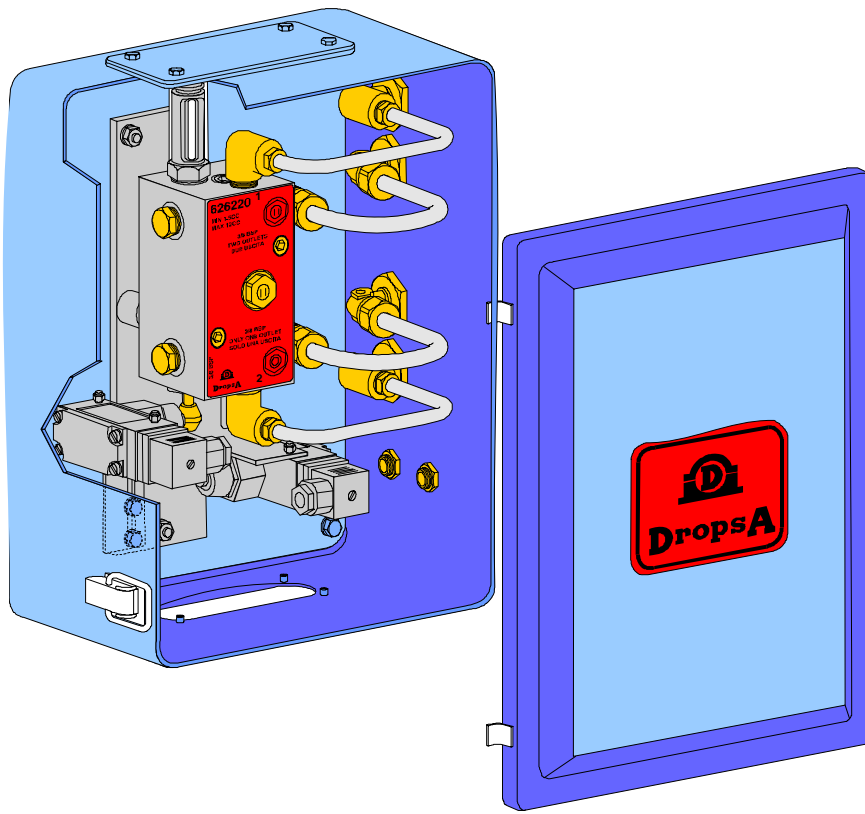

valves. They can be used when a very accurate control of the operation of the metering valves is required. Each turret on the valve is connected to a microswitch that gives a signal to electric equipment when the valve is

operated. The electric equipment controls the operation of one or more valves and gives an alarm signal if the microswitch does not give any signal within a fixed time.

ORDERING INFORMATION:

Ordering is by Part Number. Refer to the following table.

Part No.	Number of outlets	Delivery per outlet		A		B		C	
		cc.	Cu.in.	mm.	in.	mm.	in.	mm.	in.
626220	2	12	.732	295	11.614	352	13.858	185	7.283

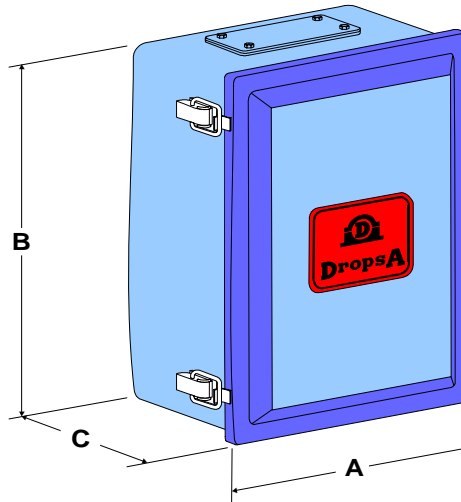



MODULAR DUAL LINE

Dual Line Lubrication Divider Valves Series 02

Series
02

PRODUCT DATA SHEET

ENGLISH

DESCRIPTION:

The modular dual line system consists of two main parts; the Base and the Metering Valves.

Bases and Metering Valves are made in stainless steel AISI 316 or in zinc plated steel and are available with inlets and outlets in UNI-ISO 7/1 (BSP) or NPTF threads.

The Metering Valves can be supplied with adjustable or fixed discharge. The Valves with adjustable discharge are fitted with turrets provided with integral adjusting screws together with a metacrylate cover and seal.

A blanking plate to be ordered separately, can be provided on the Base to accommodate future additional points.

The advantages of the Modular Dual Line System are:

- Versatility in lubrication layout planning.
- Flexibility to expand or reduce the number of elements to meet changing requirements.
- Reduced spare parts, fewer parts in stock = lower inventory costs.
- Blanking plates can be provided to accommodate future requirements.
- Save on labour and piping costs; the Metering Valves can be serviced without disturbing the assembly or existing pipework.
- Lower maintenance costs; the modular concept provides lower cost replacement components.



SPECIFICATION:

Temperature range:	-30°C to +80°C
Frequency:	100 cycles/minute.
Max. pressure (inlet):	400 bar
Lubricant:	
Min Viscosity:	100 cSt
Grease Max.:	265 ASTM (NLGI 2)*.
(*) For different type of grease please contact your supplier	
Base threads:	
Inlets:	3/8" BSP or 3/8" NPTF.
Outlets:	1/4" BSP or 1/4" NPTF.

INSTALLATION/OPERATION:

The Base:

A modular base is made up of a minimum of three elements: inlet; intermediate and end.

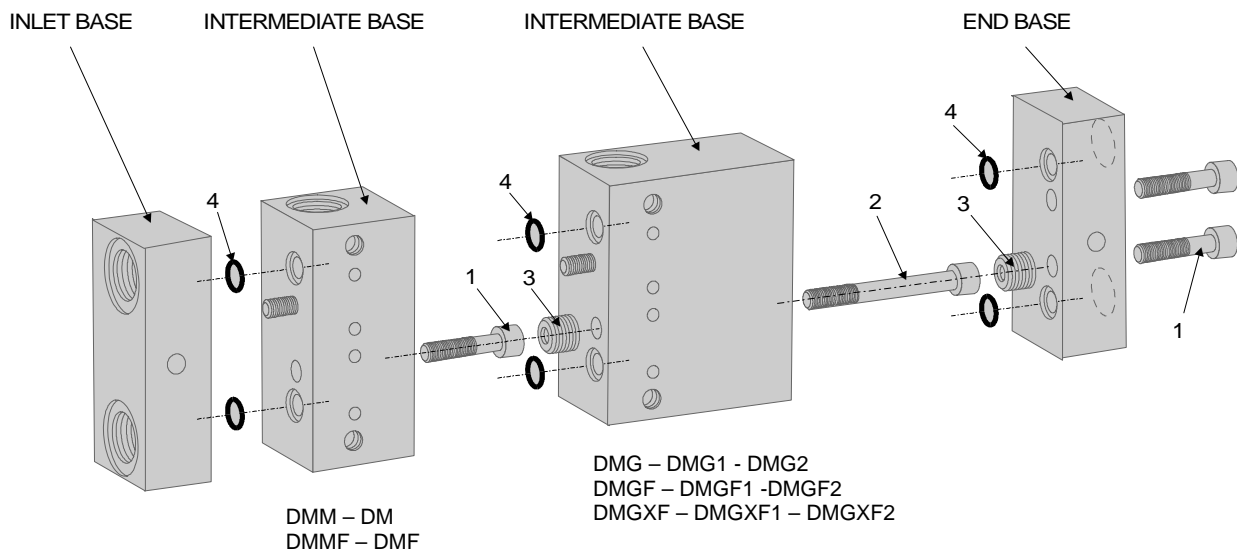

POMAC
LUB SERVICES BVBA

Kortrijkstraat 187 B-8770 Ingelmunster

Tel. +32 (0)51 316 205 - Fax +32 (0)51 309 621 info@pomac.be - www.pomac.be

Turret cover:

Turret cover.		
Part No.	Material	Mark
622207	Transparent	DMM
622210	Alluminium	DMMX
671028	Transparent	DM-DMX
675524		DMG-DMGX
675525		DMG1-DMGX1 DMG2-DMGX2

Base for valves	Value
DMM-DM-DMMF-DMF-DMMX-DMMXF-DMX-DMXF	34,7 mm. (1.366 in.)
DMG-DMGF-DMG1-DMGF1-DMG2-DMGF2-DMGX-DMGFX-DMGX1-DMGX1-DMGX2-DMGX2-DMGX2	69,4 mm. (2.732 in.)

Dimensions:

(Values in parenthesis are for fixed discharge).

Dimension 'A' is obtained by adding to the dimensions of the Base Inlet and Base End 43,8 mm. (1.725") the following values for each Intermediate Base

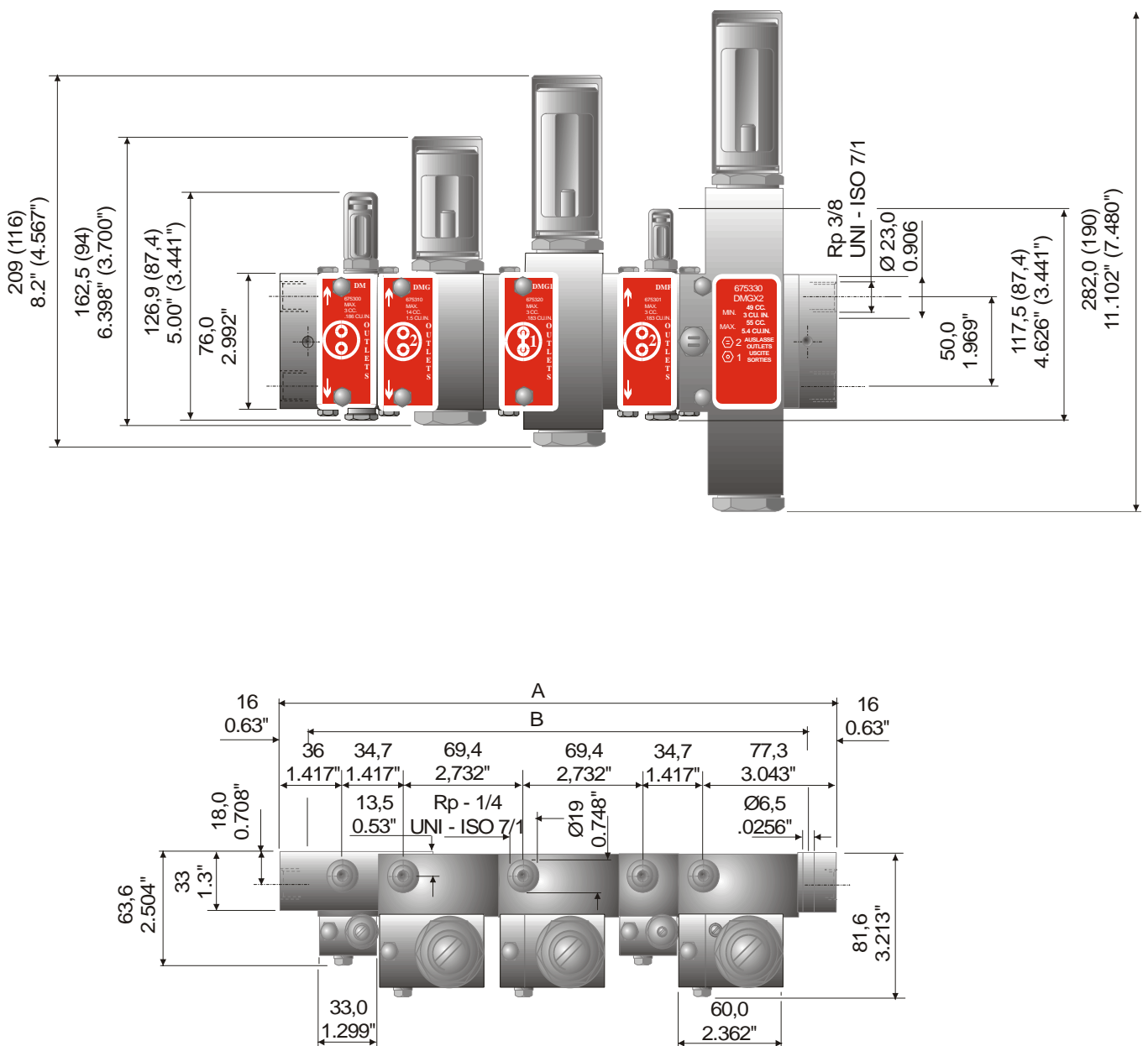

Spares:

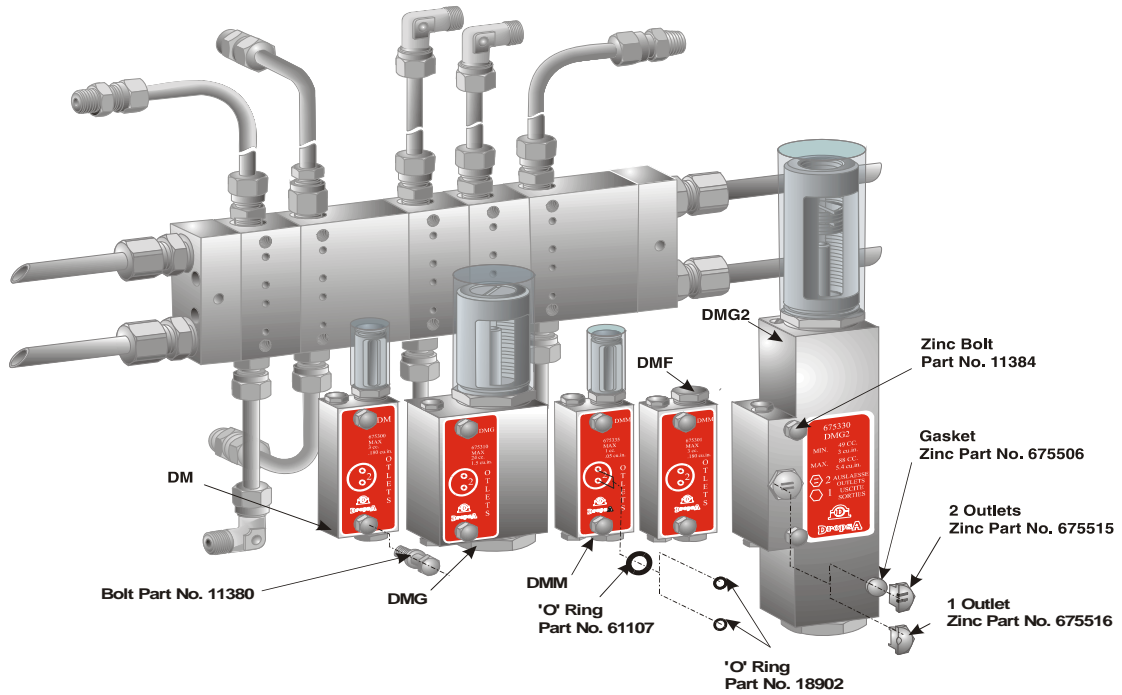

ORDERING INFORMATION:

Refer to the following ordering menu:

ORDERING MENU

NPT BSP-DIN	SEALS V VITON (Std.) S SILICONE	OUTLETS T = Twin Outlets s = Single Outlet	OPTIONS E - Microswitch S.P.D.T. A - Aluminium Cover C - Clear Cover (standard)
-----------------------	--	---	---

<p>BASIC FEATURES</p> <p>ZINC</p> <p>SB01 SB07 SB02 SB08 SB03 SB09 SB04 SB10 SB05 SB11 SB06 SB12</p> <p>STAINLESS</p> <p>SB01X SB07X SB02X SB08X SB03X SB09X SB04X SB10X SB05X SB11X SB06X SB12X</p>	<p>METERING ELEMENTS</p> <p>ZINC</p> <p>ADJUSTABLE FIXED DMM DMF DM DMF DMG DMGF DMG1 DMG1F DMG2 DMG2F</p> <p>STAINLESS</p> <p>ADJUSTABLE FIXED DMMX DMVXF DMX DMXF DMGX DMGXF DMGX1 DMGXF1 DMGX2 DMGXF2</p>
---	---

ORDER EXAMPLE:- SB05 (DMTC-DMGTC-DMMTC-DBP-DMG2TC)





777000 SERIES MOTORIZED PUMPS

For Oil or Grease
Dual Line System.

777005 777271 777572
777060 777304 777207
777010 777311 777521
777040 777510 777083
777020 777560 777273
777535 777584

ENGLISH

PRODUCT DATA SHEET

DESCRIPTION:

Suitable for Oil or Grease. Maximum pressure 500 Bar (7250 psi.). The Dropsa 777000 series modular motorized pump is suitable for a wide range of applications. Once installed it is a simple operation to adjust the pressure and adjust lubricant output (using a flow control) **Part No. 3293060.**

The assembly consists of:

Motor and reduction unit.

Pump.

Reservoir.

Valves and delivery unit.

Pressure gauge.

Charging filter.

A trolley mounted version is also available. The modular construction of the pump assembly uses common components throughout the range and therefore reduces spares holding.

The double pump body has two outlets which can either be combined together for one outlet or feed to two independent systems.

In the case of a Dual Line System the two pump outlets would operate an inverter.

Access to the pump is simple through the reservoir lid or through the covers surrounding the pump and reduction unit.

Re-filling of the reservoir is recommended through the charging filter to eliminate any ingress of contaminants. The frequency of operation can be monitored with Dropsa Control Panels or through the machines P.C.

SPECIFICATION:

Lubricant: Oil or Grease.
Delivery *: 130 cc/min. (8 cu.in./min.) with 1500 r.p.m. 4-pole motor.
Maximum pressure: 500 bar (7100 psi.).

(*) For pumps with different delivery please contact your supplier



Viscosity:

Oil min. 100 cSt.
Grease max. 265 ASTM (NLGI 2)*.

(*) For different type of grease please contact your supplier

Pump:
Delivery line:
Reservoir capacity:

Double body type 4 pistons.
Single or double.
10, 30 & 100Kg.
(22, 66 & 220 lb.)

Three phase motor:

220/380V 50/60Hz. 4 poles.
1500 r.p.m. 0.37kW up to 0 °C (+32 °F), 0.75kW up to -30 °C (-86 °F). Specify voltage and frequency when ordering.

Protection:
Reduction unit:
Temperature range:

IP44.
1:15 ratio.
Refer to motor type values

ORDERING INFORMATION:

Ordering is by Part No. Please refer to the this table:

Reservoir Kg.	Reverser	Grease		Oil	Pump weight Kg.	
		With impeller unit for hard grease			Complete with minimum and maximum level	Oil
		1	2			
10	mechanical	777005	777393	777510	31,5	35
	hydraulic	777060	-	777560		
30	mechanical	777010	777207	777521	35	40
	hydraulic	777040	777273	777572		
100	mechanical	777020	777271	777535	42,5	50
	hydraulic	777083	-	777584		

- Motor 0,37 kW.
- Motor 0,75 kW.



Kortrijkstraat 187 B-8770 Ingelmunster

Tel. +32 (0)51 316 205 - Fax +32 (0)51 309 621 info@pomac.be - www.pomac.be

Hydraulic diagrams:

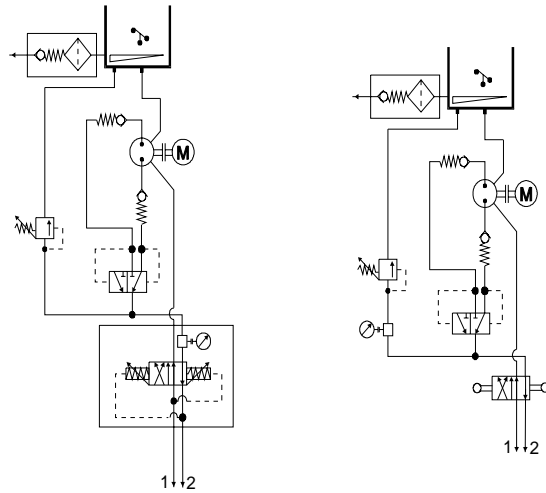
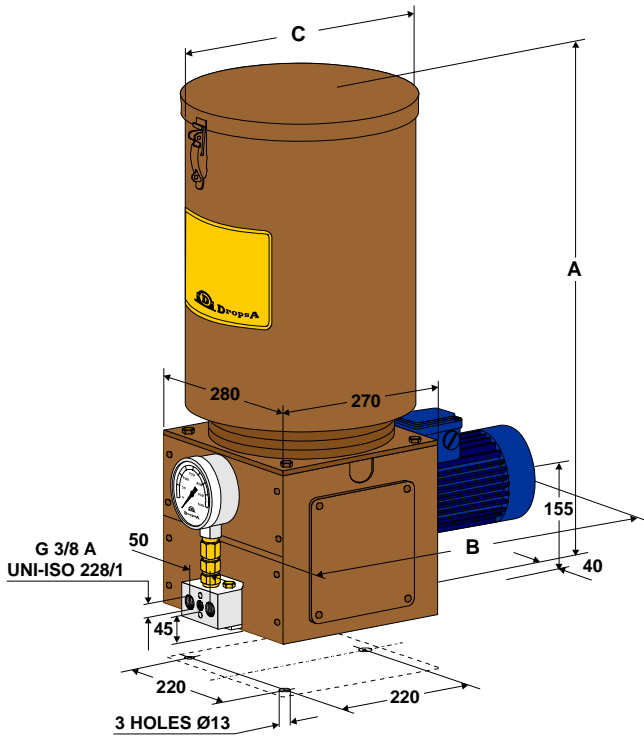

WITH HYDRAULIC REVERSER

WITH MECHANICAL REVERSER

INSTALLATION/OPERATION:

Reservoir Kg.	Dimensions mm.		
	A	B	C
10	580	520	262
30	760	520	320
100	985	520	451

MOBILE VERSION WITH TROLLEY, HOSES, QUICK COUPLINGS AND SHUT-OFF VALVES:

The pump has a standard kit identical to the other version Plus hoses, quick copulings and shut-off valves.

OVERALL DIMENSIONS:

Height: 1017 mm.
Width: 475 mm.
Depth: 730 mm.

Equipped with hose 12m long (complete with safety pin)

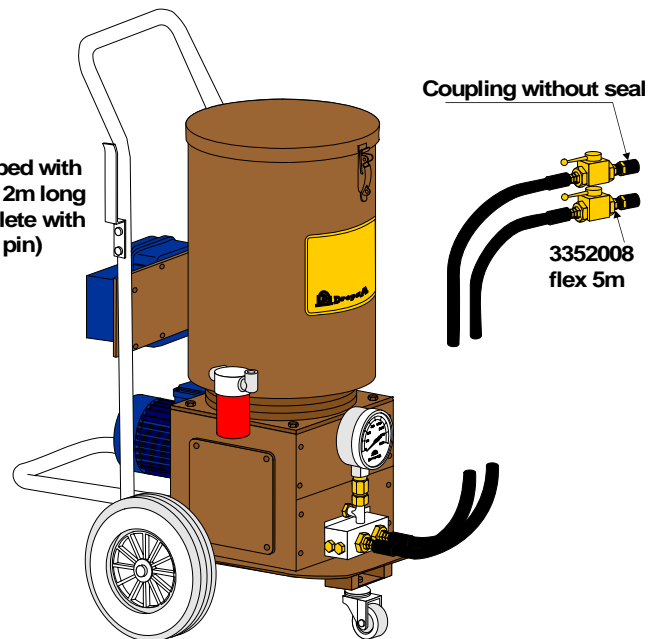

Motor	No. of poles/RPM	Part No. with reservoir.		Pressure Bar (Mpa)	Delivery Cm ³ /min.
		10Kg. (10daN)	30Kg. (30 daN)		
Three phase 220/380 V 50Hz.	4	777959	777961	200 (20)	130
Three phase 220/380 V 50Hz.	2	777962	777963	200 (20)	260
Single phase 220 V 50Hz.	3000 rpm.	777964	777965	200 (20)	200



TROLLEY MOUNTED MOTOR DRIVEN PUMP 777000

For Grease with Continuous or Intermittent Flow Gun

777950 777951
777952 777953
777954 777955

ENGLISH

PRODUCT DATA SHEET

DESCRIPTION:

Mobile lubrication unit, delivers 130 cc. (.28 lb.) of lubricant per minute with a back pressure of 400 bar (5700 psi.), or 260 cc. (.57 lb.) at 200 bar (2850 psi.). The piston pump has a double pumping impeller and is available with 4 or 2 pole three-phase AC or single-phase DC brush motor. The pump is supplied with a filter located under the impeller to prevent entry of foreign bodies into the suction chamber. When removed from the trolley it becomes a fixed lubrication unit for the most various applications.

The unit is complete with:

Impeller suitable for the suction of greases with a low penetration index.

Double body pump.

Motor with geared unit.

Pressure regulating valve.

Pressure switch, stops the motor when the maximum pressure is reached in the line; on operating the gun the motor restarts.

2000 mm. (78 in.) long hose Part No. 2513005 – Part No. 2513021 (length to be specified when ordering).

Continuous or intermittent flow gun.

1000 mm. (390 in.) long electric cable with earthing socket.

320 mm. (12.5 in.) dia. Rubber wheels.

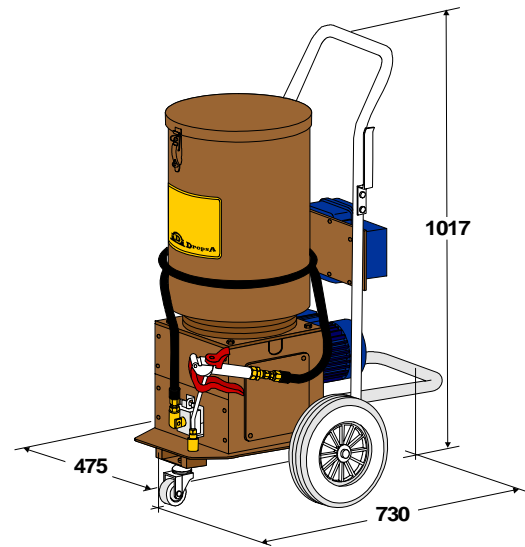

SPECIFICATION:

Lubricant:	Oil or Grease.
Delivery:	Please see table below.
Maximum pressure:	500 bar (7100 psi.).
Viscosity:	Oil min. 100 cSt. Grease max. 265 ASTM (NLGI 2)*.
Pump:	Double body type 4 pistons.
Delivery line;	Single or double.
Reservoir capacity:	10, 30 & 100Kg. (22, 66 & 220 lb.)
Three phase motor:	220/380V 50/60Hz. 4 poles. 1500 r.p.m. 0.37kW up to 0°C. (32oF), 0.75kW up to -30°C. (- 86° F.) Specify voltage and frequency when ordering.
Protection:	IP44.
Reduction unit:	1:15 ratio.
Temperature range:	Refer to motor type values.

(*) For different type of grease please contact your supplier

ORDERING INFORMATION:

Ordering is by Part No. please refer to the following table:

Motor	No. of poles/RPM	Part No. with reservoir.		Pressure Bar (Mpa)	Delivery Cm ³ /min.
		10Kg. (10daN)	30Kg. (30 daN)		
Three phase 220/380 V 50Hz.	4	777950	777951	400 (40)	130
Three phase 220/380 V 50Hz.	2	777952	777953	200 (20)	260
Single phase 220 V 50Hz.	3000 rpm.	777954	777955	200 (20)	200

Motors with different voltage, frequency and protection degree are to be specified when ordering along with CSA motor specs.

**INSTALLATION/OPERATION:
HYDRAULIC DIAGRAM:**

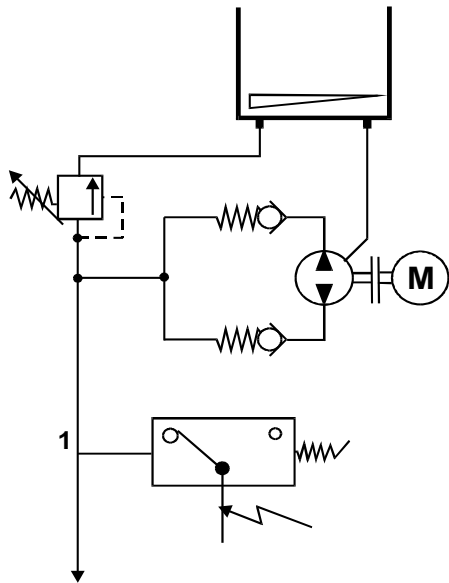

Lubrication examples:

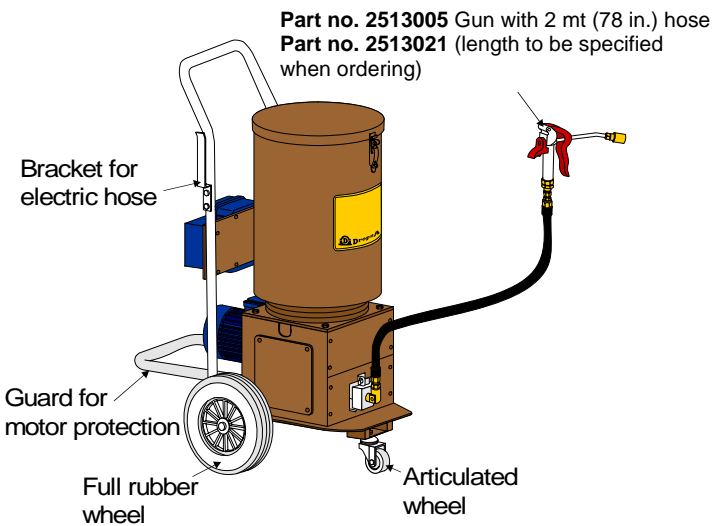

This type of lubrication unit represents the mobile version of the 777000 series grease electric pumps, whose features and versatility remain totally unchanged. Easy to use, this pump is particularly suitable for those applications requiring non-frequent lubrication cycles, thus allowing the use of a single mobile lubrication unit to feed separate installations or single lubrication points. Each unit is supplied with gun and hydraulic nipple and can be equipped on request with the accessories shown aside. It also has a pressure switch, which stops the motor when maximum pressure setting is reached.

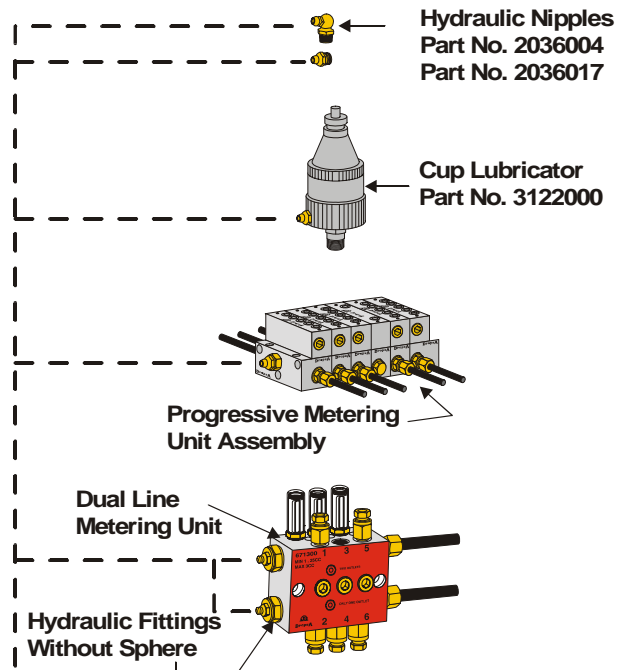

Spare parts with quick-coupling for gun connection to be ordered separately

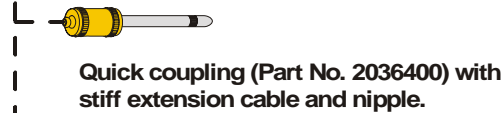

Quick coupling (Part No. 2036400) with stiff extension cable and nipple.



Quick coupling (Part No. 2036401) with flexible extension cable and nipple.

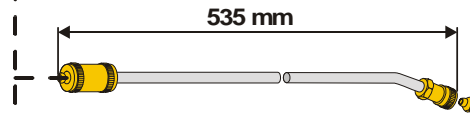

Quick coupling (Part No. 2036403) with stiff extension cable and nipple.

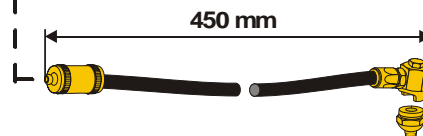

Quick coupling with hose and buttonhead connector:
Standard: Part No. 2036521
Giant: Part No. 2036522

For other types of installation please refer to catalogue 07



MODULAR MOTOR DRIVEN PUMPS 999000 SERIES

For Oil or Grease.

999000

ENGLISH

PRODUCT DATA SHEET

DESCRIPTION:

Modular pumps particularly suitable for the lubrication of small or medium size machinery. They are used for different types of oil and grease lubrication systems and in a very large range of applications because of their high quality, high performance and low cost.

The modular construction of 999 series pumps enables easy dismantling for maintenance, guarantees very high reliability and allows very fast adjustment of the units for different operating conditions.

Basic modules:

Electric Motor.

Reduction Unit.

Single or Double Pumping Unit.

Reservoir.

Steel sheet reservoirs are equipped with low level indicator and electric contact. Reservoirs for oil are equipped with re-filling filter.



Ordering information:

Type of motor and R.P.M.*	Adjustable delivery				Max. Press. bar (psi.)	Part No. of Motor Driven Pump 999000 Series Metal Reservoirs Capacity							
	Cm ³ /min		Cu.in./min.			Grease Max. NLGI 3.				Oil Viscosity Min. 15 cSt			
	Min.	Max.	Min.	Max.		3Kg. 6.6lbs.	5Kg. 11lb.	10Kg. 22lb.	30Kg. 66lb.	3 Lt.	5 Lt.	10 Lt.	30 Lt.
A.C. 1500 R.P.M.	1,4	8,5	,08	,6	750 (11000)	999234	999214	999224	999204	999244	999264	999274	999254
	2,5	17	,15	1	400 (5800)	999236	999216	999226	999206	999246	999266	999276	999256
	5	33	,30	2	200 (2900)	999232	999212	999222	999202	999242	999262	999272	999252
A.C. 1500 R.P.M.	Fixed delivery				750 (11000)	999334	999314	999324	999304	999344	999364	999374	999354
	8,5		,6		400 (5800)	999336	999336	999326	999306	999346	999366	999376	999356
	33		2		200 (2900)	999332	999312	999322	999302	999342	999362	999372	999352

R.P.M.* and lubricant deliveries indicated in the table refer to 50Hz. motors. With 60Hz. motors speeds and deliveries are increased by 20%.

Assembled pumps with hydraulic reversing:

Pump Assy. Part No.	Adjustable delivery cm ³ /min.	Driven air pressure bar	Grease Reservoir Kg.	Pump Part. no	Kit part no.
999525	2,5 ÷ 17	300 *	30	999206	299462
999510	5,0 ÷ 33	200	5	999212	299474
999527	5,0 ÷ 33	200	10	999222	299474
	Fixed delivery cm ³ /min.				
999506	17	300	30	999306	299462
999533	33	200	10	999322	299474
999540	33	200	30	999302	299474

SPECIFICATION:

Operating pressure: up 75Mpa
(750 bar) (11000 psi.)

Delivery:
Fixed. up to 33 cm³/min- 1500 r.p.m.
Adjustable. up to 51cm³/min. - 2200 r.p.m.

Lubricant: Oil viscosity 100 cSt min.
Grease NLGI 2*

* at the operating lubricant temperature between -20°C to +100°C

MOTORS:

A.C. Motors:

Code 3301137 Three phase 220/380V - 50Hz - 0.12kW

Code 3301269 Single phase 220V - 50Hz - 0.12kW

D.C. Motors:

Code 3301283 24V 120W

Code 3301274 12V - 100W

Specify voltage frequency and phase when ordering.

INSTALLATION/OPERATION:

Hydraulic diagram.

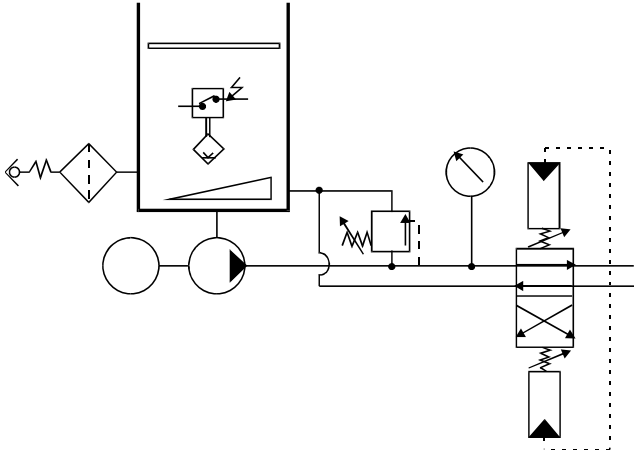

Dimensions.

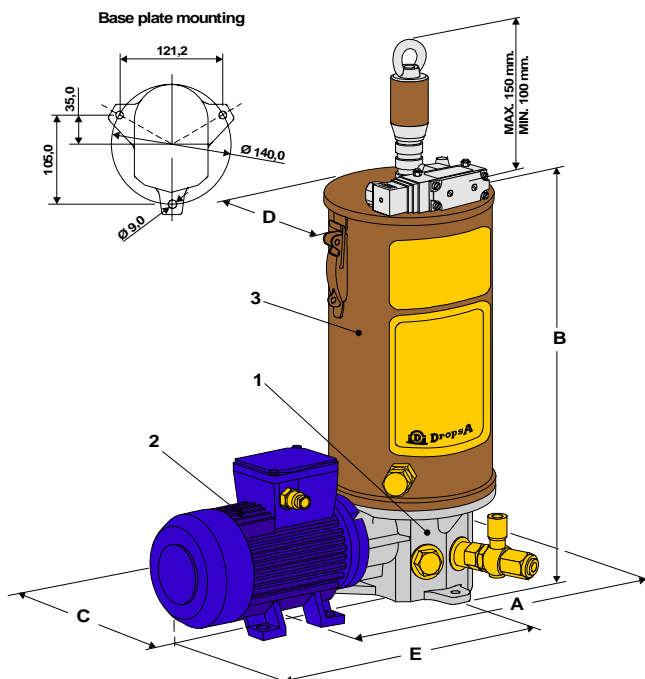

Pump Kg./l	Dimensions mm.				
	A	B	C	D	E
3	390	340,5	220	Ø160	292
5	390	400,5	220	Ø160	292
10	442	505	220	Ø262	292
30	472	673	220	Ø262	292

ACCESSORIES:

Auxiliary Pumping Unit.

Pumps are supplied with one pumping unit but are designed for the mounting of two pumping units. This allows a feed to two separate lines or the outlets of the pumping units may be combined to provide double the delivery to a single line.

Part numbers of second pumping units are given in the table below.

Last digit of pump Part No.	Features of 999 pump			Second pumping unit	
	Delivery cm ³ /min.		Pressure bar	Part No./delivery	
	Adjust	Fixed		Adjust	Fixed
4	1,4-9,5	9,5	750	299041	299039
6	2,5-17	17	400	299042	299040
2	5-33	33	200	299042	299040

Re-filling Filter. (for grease reservoir)

Removable filter cartridge, to prevent contaminants and foreign bodies from entering the reservoir and to prevent air bubbles forming in the grease..

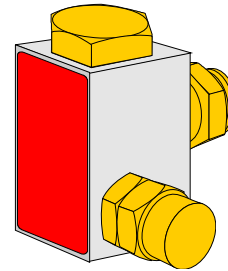

Part No. 299352 for metal reservoirs.

Part No. 299353 for transparent reservoirs.

Thread G ½ A UNI-ISO 228/1. Cartridge (150 micron)

Part No. 1113006. The filter is provided with thread Rp ¼ UNI-ISO 7/1 for the return line into the reservoir.

Safety By-pass Valve.

Available for different pressure ranges this adjustable valve can be fitted on the outlet line. It protects the system from over pressure.

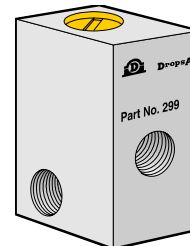

Part No.	Pressure range.
299450	0 to 250 bar (0 to 3600 psi.).
299451	0 to 350 bar (0 to 5100 psi.).
299452	50 to 1000 bar (725 to 14500 psi.).

Max. Electric Level Contact.

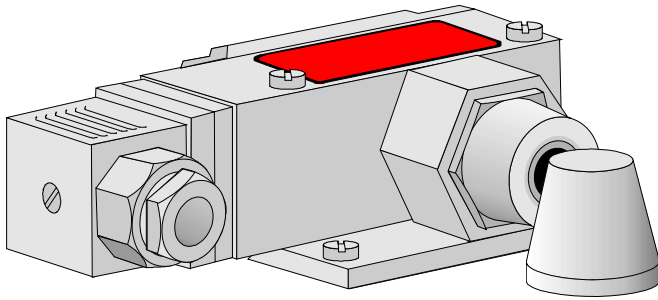

All metal reservoirs (except 3 and 5 litres) can be equipped with a Max. electric level contact for automatic re-filling of the reservoir.

Reservoirs for grease.

Electric contact **Part No. 299197.**

Reservoirs for oil.

Electric contact **Part No. 291155.**

Pressure Gauge.

Available for different pressure ranges.

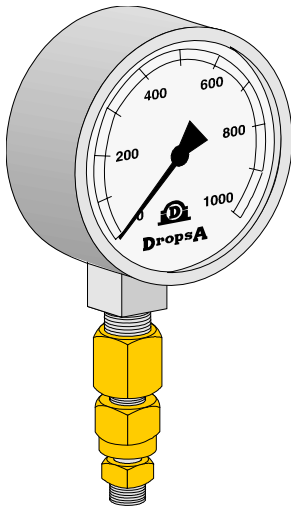

Part No. 299196 0 to 500 bar.

Part No. 291395 0 to 1000 bar.

Assembly Kit for Dual Line with hydraulic reverse-gear

999 series pumps can be equipped with a kit consisting of: Re-filling Filter; Pressure Gauge; Safety By-pass Valve and Base Plate. To order the Assembly Kit see the table below.

Last digit of pump Part No.	Assembly Kit with By-pass Valve	
	1 Pumping unit	2 Pumping Units
4	299462	299463
6	299462	299463
2	299474	299475

Change Over Valve (Inverter).

For use with Dual Line Systems. An adjustable change over valve (automatic change over when the pressure exceeds a fixed value) available in the following types:

Hydraulic Inverter.

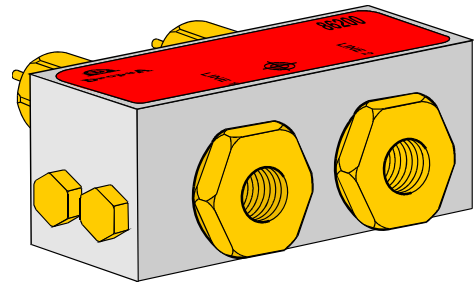

It controls automatically the lines' pressurisation inversion when the pressure value set on the adjusting valve is reached.

Part No. 86198 for pressures up to 50 bar.

Part No. 86199 for pressures up to 300 bar.

Part No. 86200 for pressures up to 200 bar.

Electro/pneumatic Inverter.

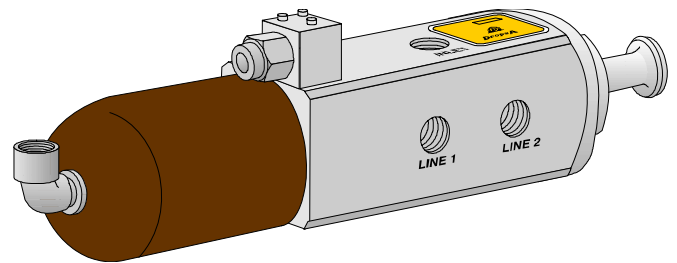

It controls the lines' pressurisation inversion through a solenoid valve connected to the system's electrical equipment and to the end of line pressure switch.

For pressures up to 500 bar.

Part No. 83300 with electric valve 110V – 50Hz.

Part No. 83304 with electric valve 220V – 50Hz.

Part No. 83308 with electric valve 24V – 50Hz.

Part No. 83309 with electric valve 24V d.c.

Pneumatic Inverter.

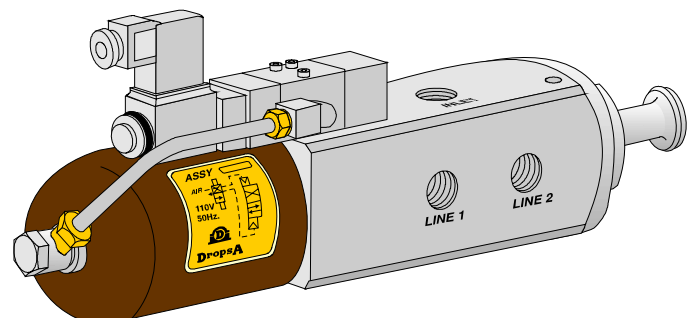

Similar to the electro-pneumatic inverter but without solenoid valve; it is operated through a pneumatically driven control directly from customer's equipment.

Part No. 83301



POMAC
LUB SERVICES BVBA

Kortrijkstraat 187 B-8770 Ingelmunster

Tel. +32 (0)51 316 205 - Fax +32 (0)51 309 621 info@pomac.be - www.pomac.be

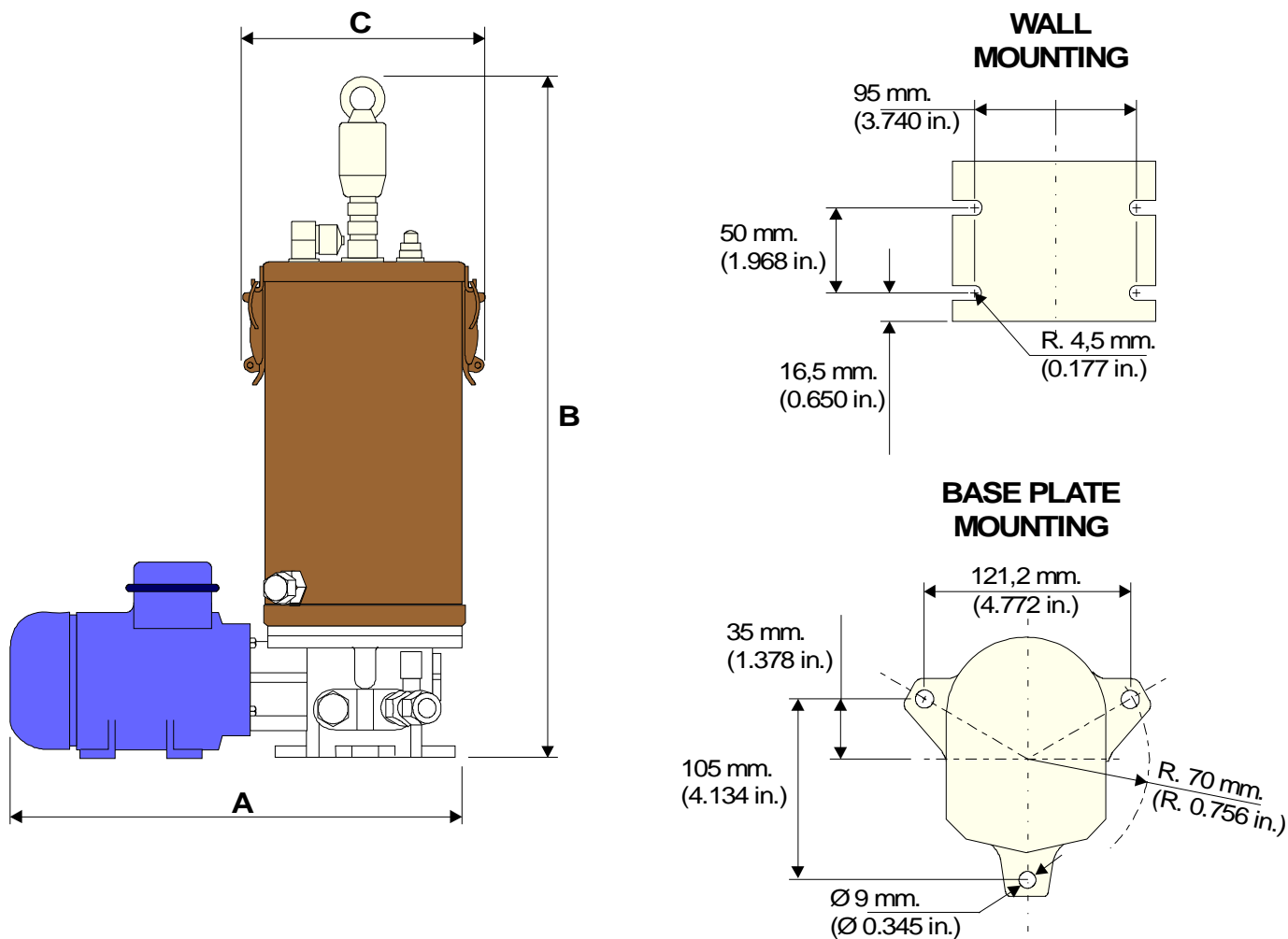

OVERALL DIMENSIONS:

D i m	Grease Reservoir										Oil Reservoir									
	3 Kg. (6.6 lbs.)				5 Kg. (11 lbs.)						3 litres (.8 US gal.)		5 litres (1.3 US gal.)		10 litres (2.6 US gal.)		30 litres (8 US gal.)			
	Trans.		Metal		Trans.		Metal		10 Kg. (22 lbs.)		30 Kg. (66 lbs.)		mm.	In.	mm.	In.	mm.	In.	mm.	In.
A	300	11.8	300	11.8	300	11.8	300	11.8	423	16.6	453	17.8	300	11.8	300	11.8	423	16.6	453	17.8
B	354	13.9	490	19.3	414	16.3	550	21.6	645	25.4	825	32.5	392	15.4	452	17.8	557	21.9	714	28.1
CØ	197	7.8	197	7.8	197	7.8	197	7.8	299	11.8	358	14.1	197	7.8	197	7.8	299	11.8	358	14.1





MANUAL PUMPS 156000 SERIES

For Oil or Grease.

156000

ENGLISH

PRODUCT DATA SHEET

DESCRIPTION:

A range of manually operated pumps for use with dual line lubrication systems. The pumps are equipped with a built in reversing device. They are suitable for either oil or grease with a lubricant discharge of 3,4 cc. For each forward and return movement of the control lever. The pressure range is adjustable from 30 to 150 bar. Outlets are 2 3/8" BSP flat sealing outlet holes. The lower body of the pump is made of galvanised steel. The piston and the small piston valves are of hardened and lapped steel. The valves which control the inversion pressure are adjustable over a range of 30 to 150 bar.

The pump body support is made of cast aluminium alloy.

The hardened and lapped steel piston is activated by a shrunk-on lever on the handle with stub coupling. The double-acting piston is controlled by small piston valves.

Line inversion occurs automatically and is indicated by the following:

- increased resistance of the operating lever.
- zero-set on the pressure gauge.
- The small pistons alternately come out from the pressure controlling valves.

SPECIFICATION:

Delivery: 3,4 cm³ for each forward and return movement of the control lever.

Pressure: 30 to 150 bar

Line inversion: 120 bar



Lubricant: Oil min. 15 cSt
Grease refer to table.

Reservoir: 1, 2 and 5 litre.

Pressure gauge: 0 to 250 bar.

Hydraulic inverter: Equipped with two valves for the control of pressure inversion. Adjustable from 30 to 150 bar.

Outlet: 3/8 UNI-ISO

Reservoir inlet: 228/1 (3/8 Gas).
1/2 A UNI-ISO 228/1 (1/2 Gas).

ORDERING INFORMATION:

Please refer to the following table.

Pumps for Oil							
Pump with reservoir	Oil Litre.	Weight Kg.	Note	Dimensions mm.			
				A	B	C	
156080	5	7,8	Reservoir with visual level indicator.	420	275	---	
156085	1	5,8	Reservoir without visual level indicator.	310	199	---	
156090	2	6	Reservoir with visual level indicator.	459	199	---	
Pumps for Grease							
Pump with reservoir	Grease Kg.	Weight Kg.	Note	Type of Grease	Dimensions mm.		
					A	B	C
156060	5	12	Reservoir with follower plate.	NLGI 1	530	282	80 to 230
156065	1	6,2	Reservoir with follower plate.	NLGI 1	313	205	20 to 182
156070	2	8,6	Reservoir with follower plate and stem.	NLGI 2	515	220,5	54 to 355
156075	2	9,6	Reservoir with rapid filling fitting.	NLGI 1	535	220,5	8,5 to 23
156095	1	7,2	Reservoir with follower plate and stem.	NLGI 2	305	220,5	53 to 158

INSTALLATION/OPERATION:

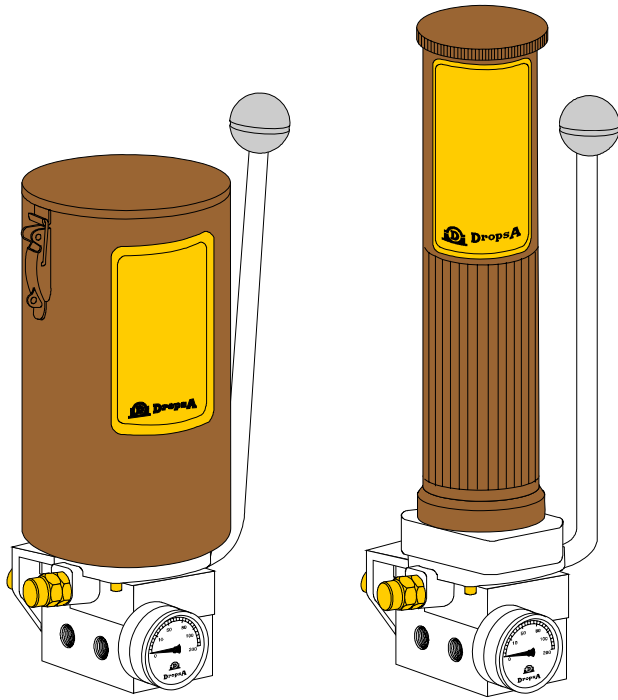

Dimensions.
Refer to table.

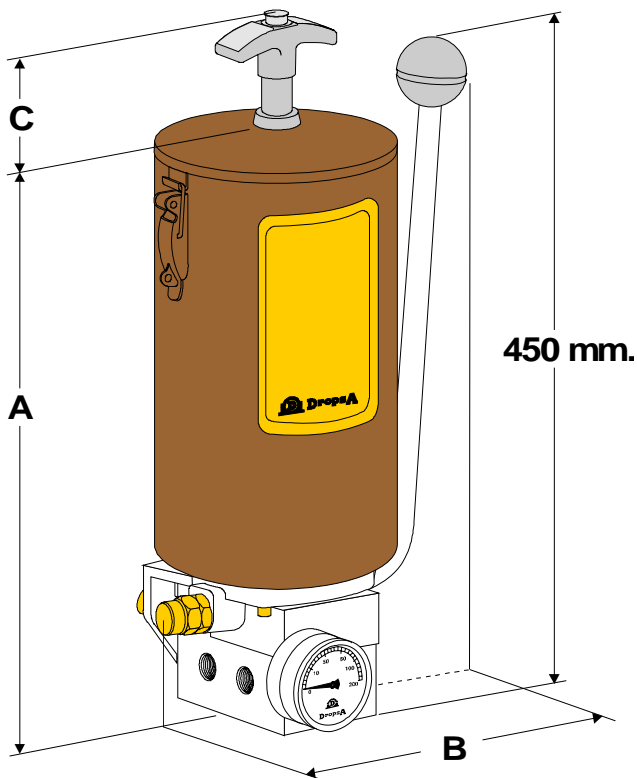

ACCESSORIES:

Mounting Plate.

For fixing 156000 series pumps.

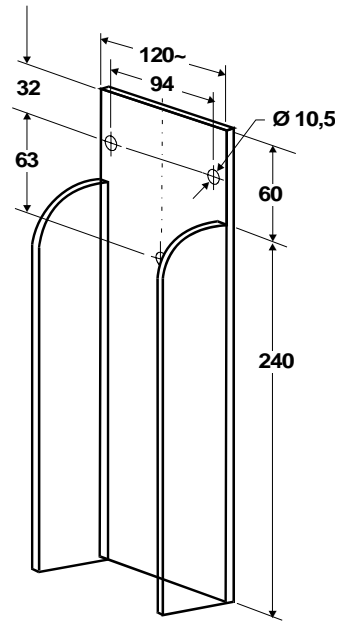

U-welded plate **Part No. 111580**

Weight: 3,70 Kg.

Filling Socket.

To fill reservoir **Part No. 1815000.**

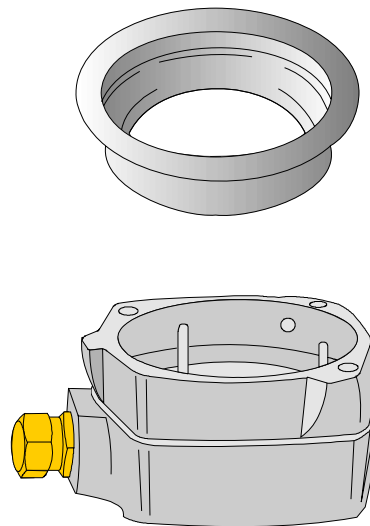

Part No. 1142000

Weight: 2,6 Kg.



PUMP 242000 SERIES

For Oil or Grease.

PRODUCT DATA SHEET

242000

ENGLISH

DESCRIPTION:

The 242 series lubrication pumps are particularly suited to the heavy industrial sector, with its features of long life, safe and constant functioning and reduced maintenance being indispensable for ensuring a perfect and efficient lubrication of machinery working under heavy and demanding conditions, and in particular where continuous operating is required to ensure a high level of production.

By selecting from a range of perfectly compatible and easily assembled components it is possible to vary the pressure, the quantity of lubricant delivered, the type of lubricant or the type of distribution.

The complete machine, mounted on a base, can be considered a true central lubrication unit with its high performance permitting an extensive layout and a high number of lubrication points.

This lubrication unit is made up of:

- a pump assembly with a robust cast aluminium pump body housing a pump element assembly with hardened, ground and lapped steel pistons.
- Three phase electric motor: 220/380V – 50 Hz-0.75 kW.
- Reduction gearbox in light alloy with a bronze helical gear wheel and a hardened and ground steel shaft. Available in three versions, with 1:10 ratio for a capacity of 450 cm³/min; 1:20 for a capacity of 225 cm³/min and 1:40 for a capacity of 110 cm³/min.
- A tank of 65 Kg (65 daN) for grease and 65 litres for oil, mounted on a support flange equipped with a lubricant reserve and minimum level signalling device and a tank filling valve (only for grease tanks)
- Electromechanical inverter to control the inversion of the lubrication lines (24V – 50 Hz solenoids standard, other voltages and frequencies on request).
- Non-return valve assembly, delivery filter and pressure regulator, mounted on the pump element assembly outlet.



Versions

Motor-driven pump		Capacity (cc/min)	Reduction gearbox	Ratio	Motor	
Oil	Grease				RPM	HP
242521	242501	450	242210	1/10	1500	1
242522	242502	225	242220	1/20	1500	1
242523	242503	110	242240	1/40	1500	1
242531	242511	450	242210	1/10	1500	1
242532	242512	225	242220	1/20	1500	1
242533	242513	110	242240	1/40	1500	1

Spare parts

Code	Description
3301129	Electric Motor
242142	Coupling, Unidirectional
242210	Reduction Gearbox 1/10
242220	Reduction Gearbox 1/20
242240	Reduction Gearbox 1/40
230002	Coupling, flexible



POMAC
LUB SERVICES BVBA

Kortrijkstraat 187 B-8770 Ingelmunster

Tel. +32 (0)51 316 205 - Fax +32 (0)51 309 621 info@pomac.be - www.pomac.be

SPECIFICATION:

Operating pressure:	up 15Mpa (150 bar) (2205 psi.)
Pump capacity:	max 450 cm ³ /min
Tank capacity:	65 litres (oil), 65 kg. (grease)
Motor:	3 ph: 220/380V – 50 Hz 1500 rpm – 0,75 kW
Reduction ratios:	1:10, 1:20, 1:40
By-pass setting:	120 bar (with internal setting system)
Min. Work time (sec):	24 (min. pause time 96 sec)
Operating temp.:	- 5°C + 40°C
Max weight kg:	140
Lubricant:	Oil viscosity 100 cSt min. Grease NLGI 2*
Grade of protection:	IP55
Insulation:	Class F

* at the operating lubricant temperature between -20°C to +100°C

Pressure Gauge.

Only one version is provided .
Part No. 20554 300 bar

INSTALLATION/OPERATION:

Hydraulic diagram

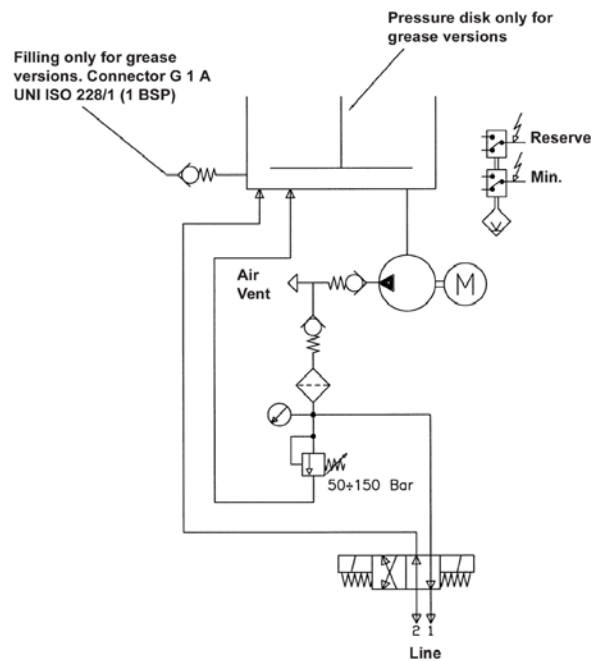

Electrical diagram

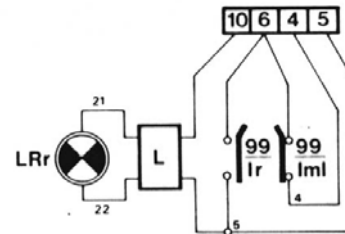
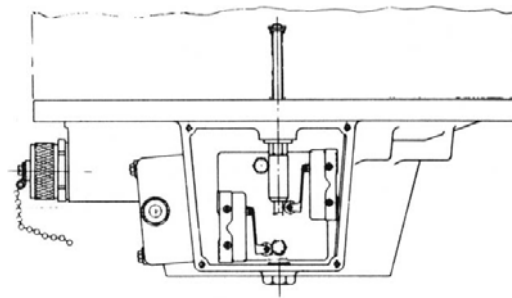

Electrical connections diagram

LRr	.Red luminous signal
L	.Blinker
99/r	.Reserve switch
99/lml	.Minimum level switch

Electrical power supply:	220 - 380 V 50 Hz
Absorbed power:	Approx. 0.75 kW

Dimensions

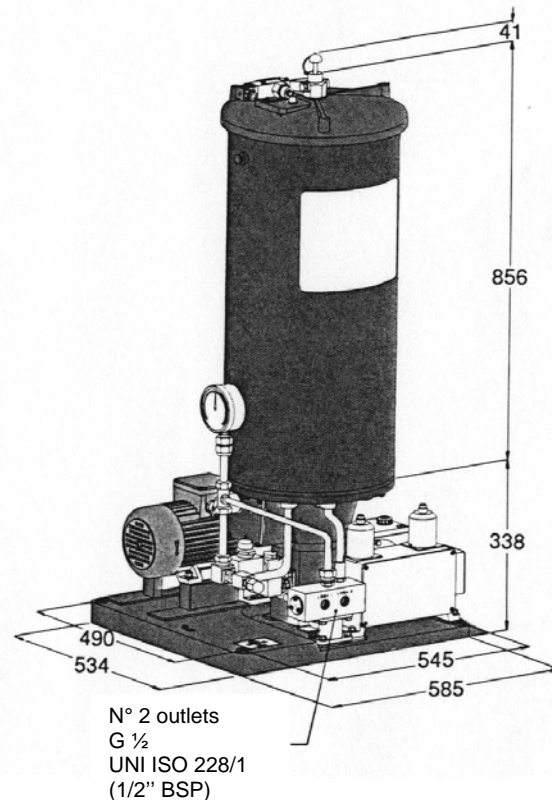



PUMP 765000 SERIES

For Oil or Grease.

PRODUCT DATA SHEET

765000

ENGLISH

DESCRIPTION:

The pump element assembly is comprised of a main piston and a piston-valve in treated ground steel which operate in a body of special tight cast iron. The capacity of the pump element piston is approximately 0.7 cc per stroke. Working pressure: 75 bar.

The alternate supplying of the lubricant to the two lines of the system is achieved through a mechanical device enclosed within the pump body.

The lubrication cycles are pre-established based on the requirements of the machinery.

The control shaft and the reduction shaft are mounted on ball bearings.

The pump is provided with a pressure control valve restricting the pressure to between 30 and 150 bar, and two pressure gauges on the main lines.

The reduction gear box, the pump element assembly and the inverter control assembly, which controls the inversion, are wet oil bath lubricated and the box they are enclosed in is not connected to the machinery lubrication lubricant tank.

This type of pump is available in four main versions:

- with a 1/15 reduction ratio
- with a 1/30 reduction ratio
- without reduction
- with oscillating control

Class of protection: Class F

Grade of protection: IP55

Operating temp.: - 5°C + 40°C

Operating humid.: 90% rel humidity

Preservation temp.: - 20°C + 50°C

Level of continuous sound pressure: < 70 dB(A)

IDENTIFICATION OF THE PART NUMBER

There are nine period assemblies for the control of the lubrication cycle interval and these can be fitted to all four types of pump. Having designed the system and selected the suitable period (see Table A), find the part number of the pump in Table B, substituting the asterisk with the selected period number.

Table A

PUMP										
PERIOD	Max. number of lubrication points per inversion with the feeders adjusted to max. flow						Max. revs to use 1400 rpm		Without reduction or with oscillating control	
	Feeder cc						Reduction ratio 1/15	Reduction ratio 1/30	Max. revs to use oil 180 – grease 100 rpm	
	1	1.5	2	3	12	27	Revs per inversion		Revs per inversion	
1°	10	7	5	3	1	-	432	864	29	
2°	20	15	10	6	2	1	864	1728	58	
3°	40	30	20	13	3	2	1728	3456	116	
4°	81	60	40	27	7	3	3456	6912	232	
5°	162	120	81	54	14	6	6912	13824	464	
6°	324	240	162	108	27	12	13824	27648	928	
7°	648	480	324	216	54	24	27648	55296	1856	
8°	1296	960	648	432	108	48	55296	110592	3712	
9°	2592	1920	1296	864	216	96	110592	221184	7424	
ELECTRICALLY DRIVEN PUMP										
PERIOD	Max. number of lubrication points per inversion with the feeders adjusted to max. flow						1400 rpm motor			
	Feeder cc						Time interval between one inversion and the next		Number of inversions in 8 hours	
	1	1.5	2	3	12	27	reduction 1/15	reduction 1/30	reduction 1/15	reduction 1/30
1°	10	7	5	3	1	-	18"	36"	1600	800
2°	20	15	10	6	2	1	36"	1'12"	800	400
3°	40	30	20	13	3	2	1'12"	2'24"	400	200
4°	81	60	40	27	7	3	2'24"	4'48"	200	100
5°	162	120	81	54	14	6	4'48"	9'56"	100	50
6°	324	240	162	108	27	12	9'56"	19'12"	50	25
7°	648	480	324	216	54	24	19'12"	38'20"	25	12.5
8°	1296	960	648	432	108	48	38'20"	1h 16'40"	12.5	6.25
9°	2592	1920	1296	864	216	96	1h 16' 40"	2h 33'20"	6.25	3.125



Kortrijkstraat 187 B-8770 Ingelmunster

Tel. +32 (0)51 316 205 - Fax +32 (0)51 309 621 info@pomac.be - www.pomac.be

Table B

Without tank		WITH TANK FOR OIL									
		With min. level contact			With recovery			With recovery and min. level contact			
		1735015 5 lt	1711010 30 lt	176270 65 lt	1735020 5 lt	1711105 30 lt	176250 65 lt	1711205 30 lt	176280 65 lt	1711155 30 lt	176290 65 lt
H	65640*	65698*	65699*	65010*	65700*	65701*	65011*	65703*	65012*	65705*	65013*
L	76502*	76552*	76553*	76554*	76555*	76556*	76557*	76559*	76560*	76562*	76563*
M	76503*	76564*	76565*	76566*	76567*	76568*	76569*	76571*	76572*	76574*	76575*
N	65641*	65706*	65707*	65016*	65708*	65709*	65017*	65711*	65018*	65713*	65019*
O	76506*	76576*	76577*	76578*	76579*	76580*	76581*	76583*	76584*	76586*	76587*
P	76507*	76588*	76589*	76590*	76591*	76592*	76593*	76595*	76596*	76598*	76599*

Without tank		WITH TANK FOR GREASE										
		With min. level contact					With min. and max. level contact					
		1835200 5 Kg	189150 10 Kg	1813150 30 Kg	1811200 65 Kg	1835100 5 Kg	189200 10 Kg	1813200 30 Kg	1811250 65 Kg	189220 10 Kg	1813160 30 Kg	1811400 65 Kg
H	65634*	65666*	65667*	65668*	65669*	65670*	65671*	65672*	65673*	65982*	65983*	65716*
L	76500*	76508*	76509*	76510*	76511*	76512*	76513*	76514*	76515*	76516*	76517*	76518*
M	76501*	76519*	76520*	76521*	76522*	76523*	76524*	76525*	75526*	76527*	76528*	76529*
N	65635*	65678*	65679*	65680*	65681*	65674*	65675*	65676*	65677*	65984*	65985*	65717*
O	76504*	76530*	76531*	76532*	76533*	76534*	76535*	76536*	76537*	76538*	76539*	76540*
P	76505*	76541*	76542*	76543*	76544*	76545*	76546*	76547*	76548*	76549*	76550*	76551*

LEGEND			
Pump		Electrically driven pump	
H	Without reduction	Wt. 12.400 Kg.	O Motor 1400 rpm - R. 1/15
L	With reduction R. 1/15	Wt. 13.750 Kg.	P Motor 1400 rpm - R. 1/30
M	With reduction R. 1/30	Wt. 13.750 Kg.	
N	For oscillating control	Wt. 13.400 Kg.	WEIGHT: 21 Kg with base 18.5 Kg without base

N.B.: The indicated weights refer to pumps and electrically driven pumps without tank

INSTRUCTIONS FOR ORDERING VERSIONS

TIMES AND CHOICE OF PUMPS

The period is chosen in relation to the type of feeder being used and the number of lubrication points (see Table A).

The maximum number of points which can be accommodated in a system and the indicated times refer to one single inversion of the line.

It must be remembered that one complete lubrication cycle is composed of two inversions.

If dual outlet feeds are employed in a system, the number of lubrication points which can be accommodated in the system, for one complete cycle, is double that shown in the table.

When electrically driven pumps controlled by electrical devices are used, periods must be selected with the shortest inversion time.

IMPORTANT: When pumps are used without reductions or for oscillating control, do not exceed 100 rpm for a grease pump and 180 rpm for an oil pump.,

CALCULATION OF THE CONSUMPTION OF LUBRICANT IN 8 HOURS

Q= quantity of lubricant in grams in 8 hours

N= number of points served for each inversion

P= capacity in cc of the feeder

l= number of inversions in 8 hours

n= rpm

i= number of revolutions per inversion

$Q=N.P.l.0.9$ $l= Q/(P*N*0.9)$ $P= Q/(l*N*0.9)$ $N=$

$Q/(l*P*0.9)$

The value obtained is the quantity of lubricant consumed by the system in 8 hours, with the feeders adjusted to maximum capacity.

For the electrically driven pumps, the number of inversions every 8 hours is already given in the table. For the other types of pumps the number of inversions every 8 hours can be calculated using the following formula:

$l= (n*60*8)/i$ $n= (l*i)/(60*8)$

N.B.: the maximum number of points to be lubricated is indicative. The values given use only 50% of the pump capacity for each inversion. It would be possible in certain cases to increase the number of points for each inversion, while for extensive systems or those with many flexible tubes, it would be better to select a higher period to that indicated.





TRANSFER AND FILLING PUMPS SERIES 132000

For Oil or Grease and Non-corrosive Fluids.

132000

ENGLISH

PRODUCT DATA SHEET

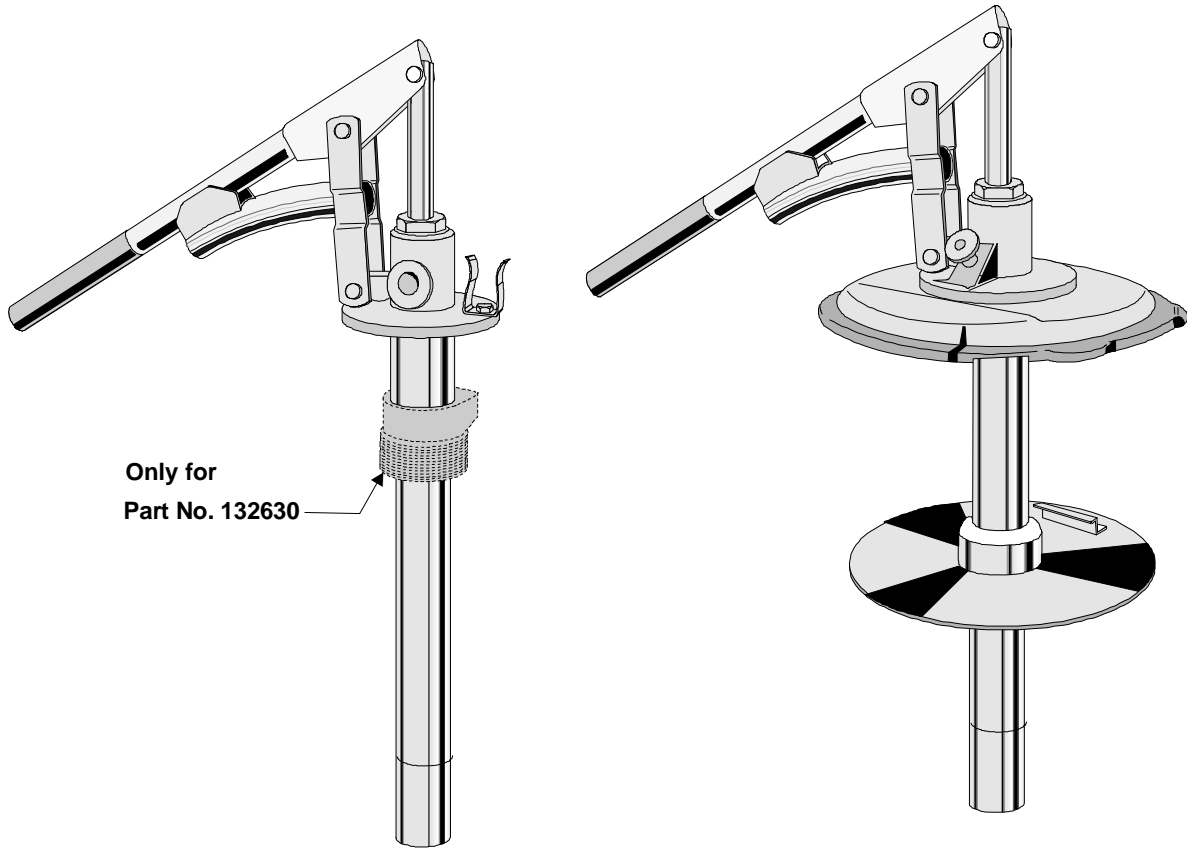

Only for
Part No. 132630

DESCRIPTION:

Piston pumps equipped with suction hose. Discharge .050 Kg. (.11 lb.) of lubricant per stroke with a back pressure of 35 bar (500 psi.). A manual built in pressure release valve permits return of handle to down position without discharging lubricant. Can be used for transferring alcohol, asphalt emulsions, fuel cleaning solvents, fuel oil, benzine, lacquer thinner, vegetable oils and many other non-corrosive, non-abrasive materials.

Pumps are supplied without filter.

SPECIFICATION:

Delivery: 50 cm³ of fluid for each operation of the lever.
Pressure: 35 bar max.

ORDERING INFORMATION:

Please refer to the following table.

For drums Kg.	Pump Part No.	Cover Part No.	Follower plate (grease only) Part No.	Piston Rod mm.
200	132630	1141500	1141103	925
115	132530	1141530	1141130	690
56	132540	1141520	1141131	515
20	132550	1141545	1141140	375



POMAC
LUB SERVICES BVBA

Kortrijkstraat 187 B-8770 Ingelmunster

Tel. +32 (0)51 316 205 - Fax +32 (0)51 309 621 info@pomac.be - www.pomac.be

INSTALLATION/OPERATION:

Dimensions.

Please refer to the following table.

Pump Part No.	Dimensions			
	A mm.	B mm.	C mm.	D Internal Ø of drum.
132057	390	375	190 -	316
132550	390	375	190 -	316
132540	390	515	190 -	380
132530	390	690	190 -	486
132630	390	925	190 -	612

Hose with oil transfer valve Ø tube 13x23
Part No. 101777

Hose without oil transfer valve Ø tube 13x23
Part No. 101778

Refilling pump hose Ø tube 13x23
Part No. 101779

When ordering hoses indicate length 'L' cm.

Hydraulic diagram.

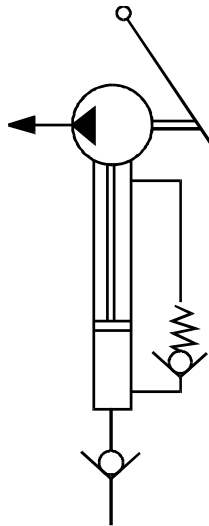

Dimensions:

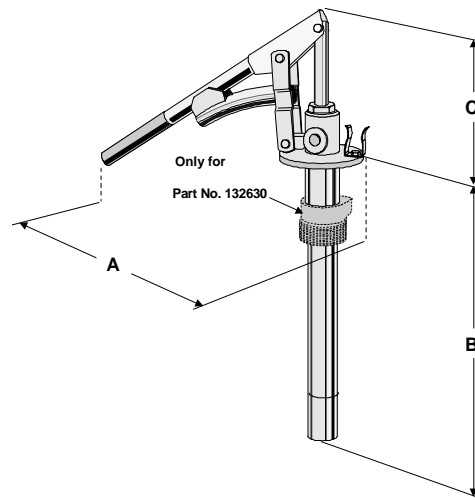

Part No's.
132630
132550
132540
132530

ACCESSORIES:

Follower plate:

It is needed when the pump is used to transfer greases (see table). Maximum grease consistency NLGI 1.

Lid:

It is used when the pump is assembled onto a drum (it replaces the original drum's cover, see table).

Oil strainer:

Part No. 1113240 thread Ø 3/8" BSP taper.
Element **Part No. 1113231**

Grease strainer:

Part No. 1113210 thread Ø 3/8" BSP taper.
Element **Part No. 1113205**

Nipple;

For pump filter joint 3/8" BSP
Part No. 133085

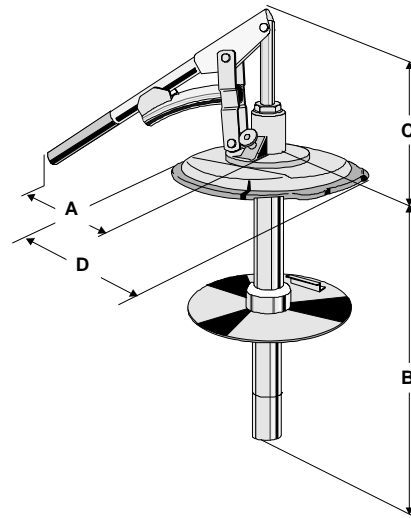

Part No's.
132057



HEAVY DUTY PNEUMATIC PUMPS SERIES 400200

For Oil or Grease and Non-corrosive Fluids.

400200
400300
400205
400210

ENGLISH

PRODUCT DATA SHEET

DESCRIPTION:

Exceptionally strong, powerful and durable pumps.
Suitable for the supply of light, heavy or fibrous lubricants, even at low temperatures.
Fits standard commercial drums or large capacity drums.

Features:

Air supply valve; complete with floating slide, held on the seat by the air pressure, self sealing and self cleaning

Positive operation; a double toggle joint correctly positions the distribution valve.

Corrosion proof steel rod; is guided to prevent faulty alignment of the air control valves, chromium plated hardened and lapped, to reduce the wear of the seals to a minimum.

Wide air discharge; to reduce the outlet air temperature drop to a minimum for maximum efficiency.

Minimum friction; the synthetic rubber air piston slides in a corrosion proof lapped aluminium cylinder.

Long life seals; accurate assembly, resilience and quality of the materials used, ensure a good seal for long periods.

No interruption for adjustment or lubrication; the air motor is sealed, there are no exposed moving parts.

Maximum life! No seal; the piston and cylinder are of special steel, treated, normalized and micro-lapped.

Double self alignment joint; with safety spring and square thread.

Sure priming; the base valve is made of hardened steel and ensures a perfect seal.

Forced feed device; makes it possible to feed very hard lubricants into the compression chamber.



SPECIFICATION:

Compression rate: see table.
Delivery: see table.
Air driven pressure: 14 bar max.
Air inlet: G 3/4 UNI-ISO 228/1

ORDERING INFORMATION:

Ordering is by description and Part No. , please refer to the following table:

Ratio	Pump Assy. Part No.	Air motor only Part No.	Piston rod only Part No.	Type of lubricant	Delivery air pressure 7 bar.
40:1	400200	400100	400170	Grease NLGI 2	8 Kg./min.
75:1	400300	400100	400155	Grease NLGI 2	5 Kg./min.
25:1	400205	400100	400165	Grease/oil 1000 cSt.	16 ltr./min.
6:1	400210	400100	400160	Oil 1000 cSt.	28 ltr./min.

Air outlet:

G ½ UNI-ISO 228/1

Dimensions.

Weight:

25 – 28 Kg.

INSTALLATION/OPERATION:

Hydraulic diagram.

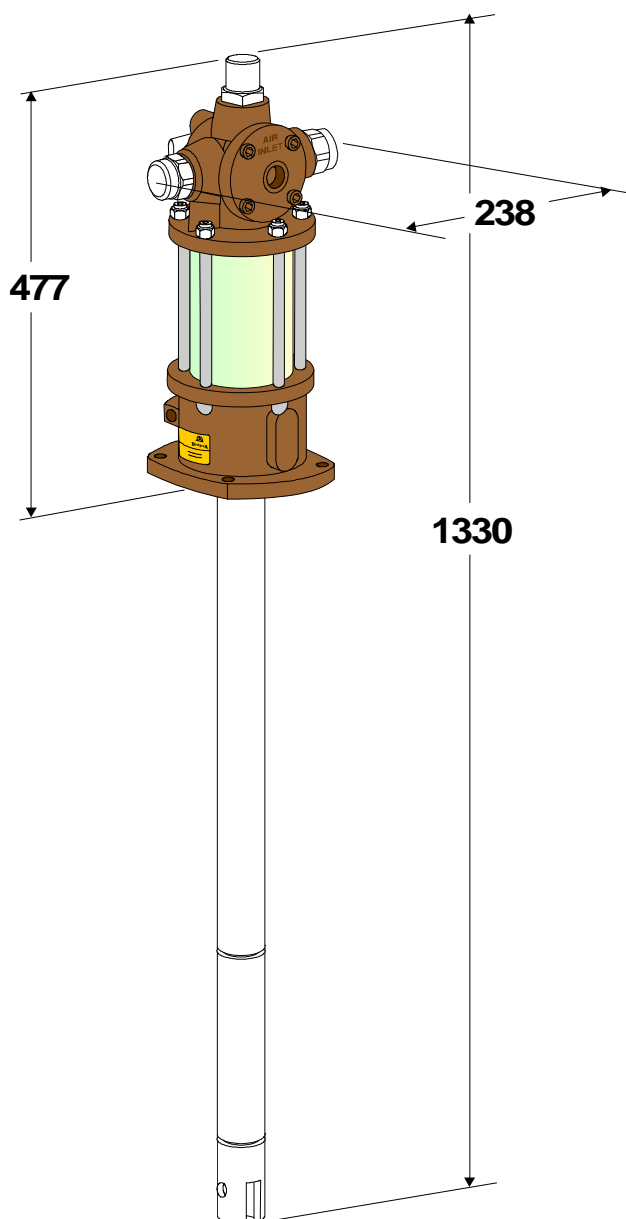
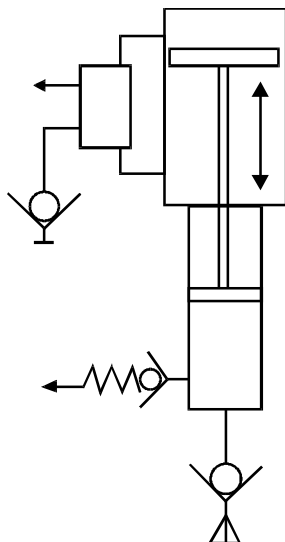

Accessories.

Exhaust silencer – Part No. 2034950

Cover for 180 Kg. Drums – Part No. 400040

Spares.

Component Part No.	Service Kit Part No.
400100	2037304
400100	2037334
400160	2037305
400165	2037306
400170	2037307
400170	400194
400170	2039930
400155	400195
400155	2034857



POMAC
LUB SERVICES BVBA

Kortrijkstraat 187 B-8770 Ingelmunster

Tel. +32 (0)51 316 205 - Fax +32 (0)51 309 621 info@pomac.be - www.pomac.be



PNEUMATIC TRANSFER AND FILLING PUMPS 72160 SERIES

For Oil or Grease and Non-corrosive Fluids.

72160
72161

ENGLISH

PRODUCT DATA SHEET

DESCRIPTION:

This type of pneumatically controlled automatic pump is suitable for transferring oil, light grease and non-corrosive fluids from 400 lb. (180 Kg.) commercial drums. It can be fixed onto the drum using a mobile bung adapter that allows the pump to be positioned at the required depth and the outlet to be pointed in any direction.

The pump is supplied complete with an air shut-off-valve and a quick release air connection. This type of pump is ideal for feeding lubricant at high pressure as the design eliminates air bubbles in the lubricant. These pumps can also be used for the transfer of alcohol, gasoline, solvents, mineral naphtha, kerosene and every other kind of non-corrosive, non-abrasive fluids.

The displacement is about 35 lb. Of grease or 2 cu. Ft. of SAE Oil per minute at a pressure of 100 psi. The pump weighs 9 Kg.

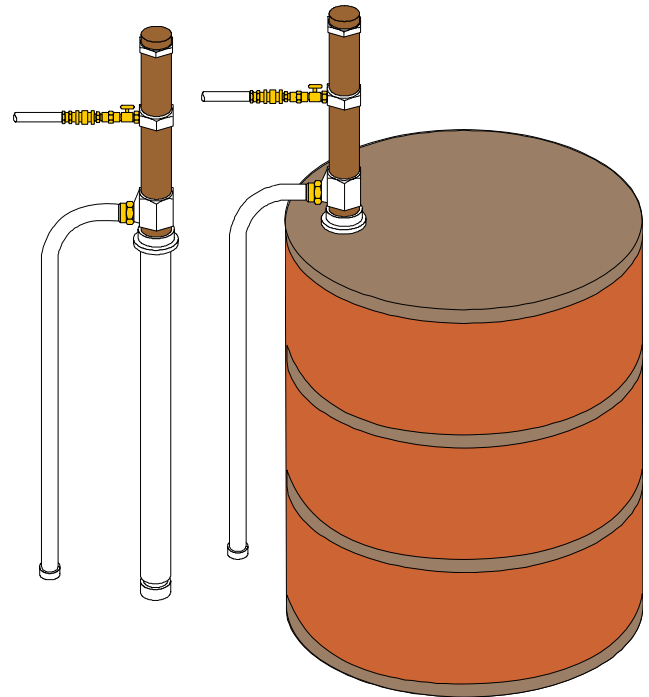

SPECIFICATION:

Recommended operating air pressure:

100 psi.

Maximum operating air pressure: 200 psi.

Maximum fluid pressure: 200 psi.

Lubricant outlet: 1" BSP (RP 1 UNI-ISO 7/1.

Air inlet: ¼" BSP (RP ¼ UNI-ISO 7/1.

Air exhaust port: Ø 5/8"

Lubricant inlet: 0,30 cm³

Displacement: Ø 168 cm³/cycle

Air consumption: 800 NL/min. at 7 bar.

Stroke: 98,5 mm.

Weight: 9 Kg.

INSTALLATION/OPERATION:

Maintenance.

The pump must be cleaned periodically and whenever there is a change in the type of fluid to be handled. For routine maintenance a repair kit **Part No. 72211** is available.

ORDERING INFORMATION:

Ordering is by description and Part No. Please refer to the following table:

Part No. and description	Weight	Air pressure	Delivery	
			Oil SAE 10	Light grease SAE 140
Standard model Part No. 72160	9	7 bar	50 Ltr./min.	25 Ltr./min.
With dispensing tube Part No. 72161	9	7 bar	50 Ltr./min.	25 Ltr./min.

Dimensions:

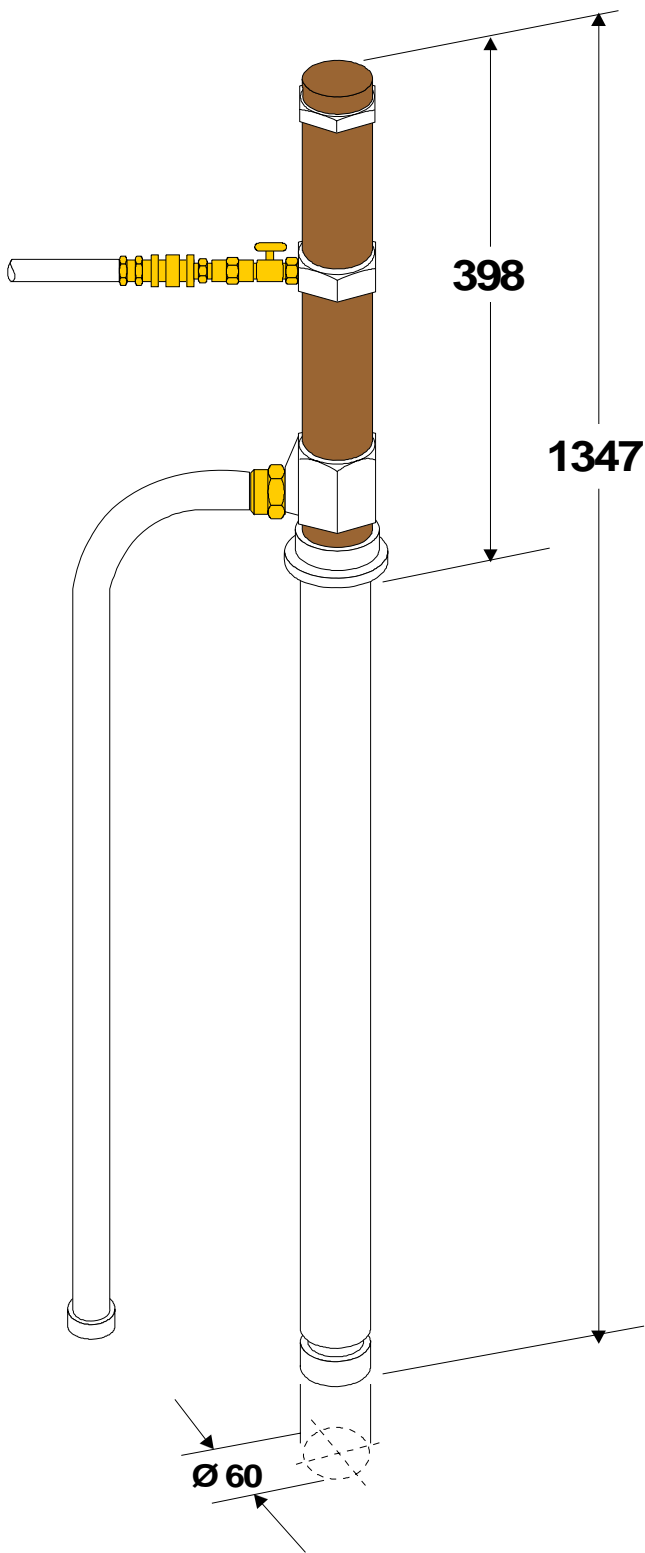

Hydraulic diagram.

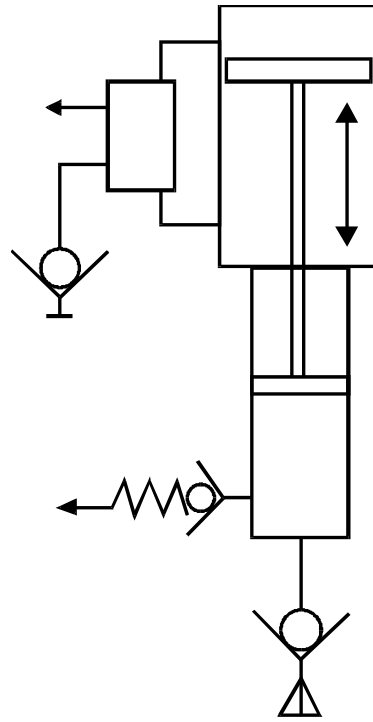

POMAC
LUB SERVICES BVBA

Kortrijkstraat 187 B-8770 Ingelmunster
Tel. +32 (0)51 316 205 - Fax +32 (0)51 309 621 info@pomac.be - www.pomac.be



MICRO SWITCH FOR FLOW CONTROL

Dual Line System

1655089 1655132
1655135 1655137
1655145 1655151
1655160 3164126

ENGLISH

PRODUCT DATA SHEET

DESCRIPTION:

These micro-switches have been designed for controlling feeder blocks of the dual line system.

- **Series AP6** (adjustable discharge 0,25 to 1,5 cm³)
- **Series AG6** (adjustable discharge 0,5 to 3 cm³)
- **Modular Dual Line Feeders Series DMM** (adjustable discharge 0,3 to 1 cm³)
- **Modular Dual Line Feeders Series DM** (adjustable discharge 0,5 to 3 cm³)
- **Modular Dual Line Feeders Series DMG** (adjustable discharge 3 to 24 cm³)
- **Modular Dual Line Feeders Series DMG1** (adjustable discharge 3 to 40 cm³)
- **Modular Dual Line Feeders Series DMG2** (adjustable discharge 51 to 88 cm³)

These micro-switches are particularly suitable for controlling the correct delivery of lubricant to critical friction points.

In order to obtain a correct movement of the piston in both directions you must mount a micro-switch on the adjusting turret of the feeder and another on the opposite side.

To choose the correct micro-switch refer to fig 1.

Warning!

The control of the correct movement of a metering piston guarantees that only the controlled feeder block is working but it does not guarantee that other feeders, not controlled on the same dual line, are working too. For this reason it is necessary to mount a micro-switch on each feeder block which must be controlled.

SPECIFICATION:

Electrical feeding: up to 10A 250V ac. or 5A
Protection degree: IP 55
Working temperature: -15°C to +80°C
Working pressure: 200 bar max.

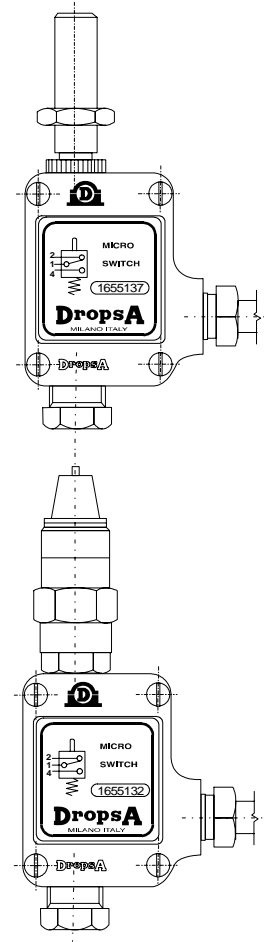

TURRET SIDE

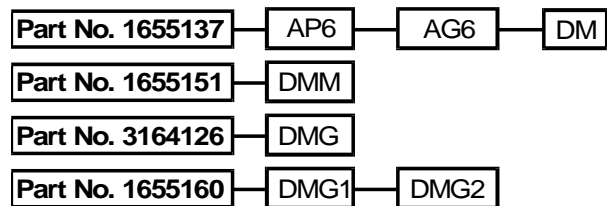

SIDE OPPOSITE THE TURRET

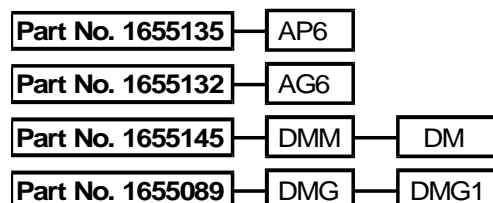

INSTALLATION/OPERATION:

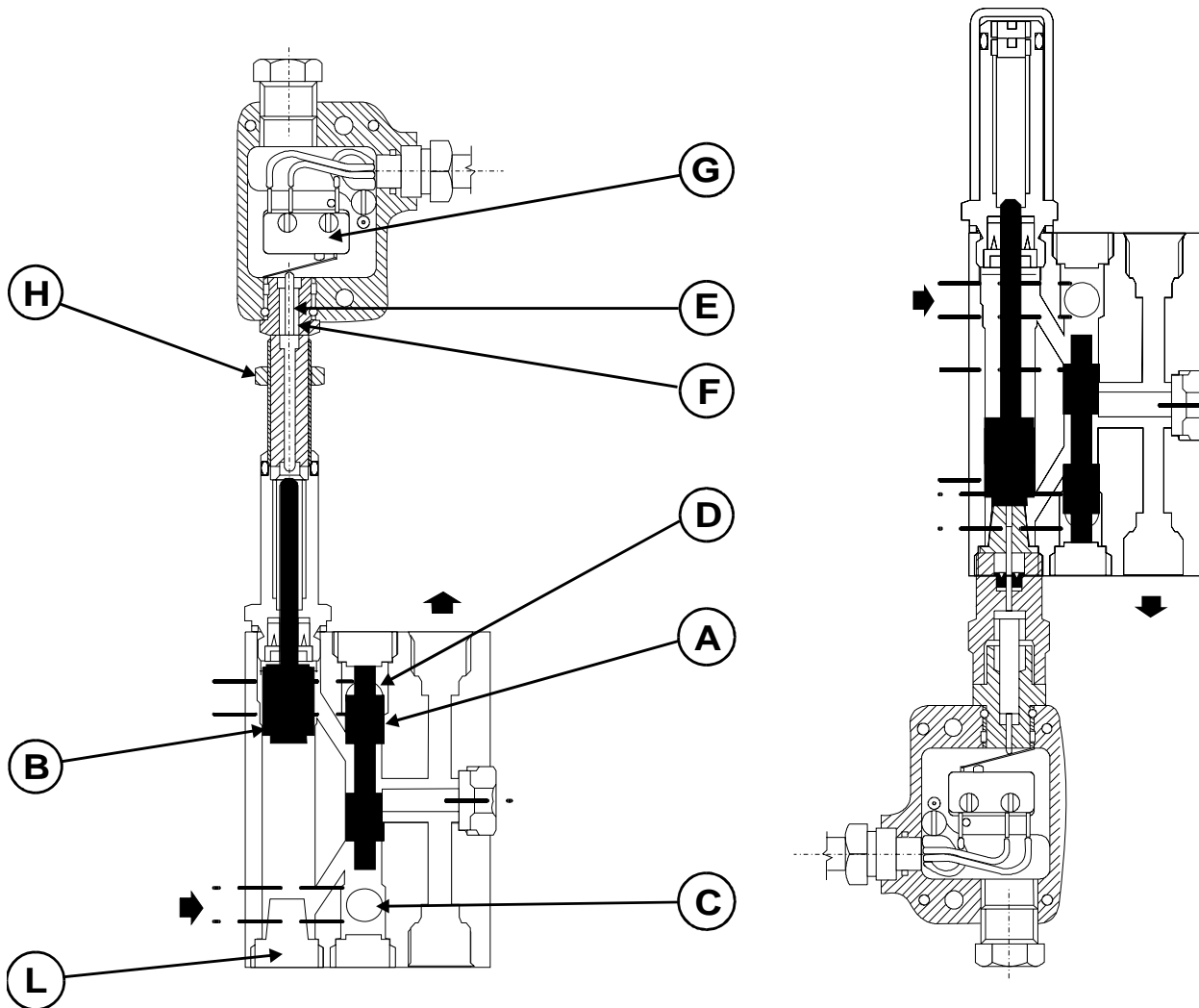

Installing micro-switch on turret side. (fig 2.)

This micro-switch is screwed directly on the indicator turret. For the installation it is necessary to remove the turret's cover and the two adjusting screws and then screw the micro-switch on the turret; after having positioned the micro-switch on the desired delivery, tighten it by means of nut 'H'.

Installing micro-switch on the side opposite the turret. (fig 3.)

These micro-switched are installed on the other side of the turret and replace plug 'L'.

For electrical connections please refer to the diagram on the label of the micro-switches' cover.

Function.

The lubricant, under pressure, enters hole 'C' and moves upwards servo piston A and metering piston B (fig. 2) . Piston B's pin pushes pin E on the micro-switch, compresses spring F and activates contact G, thus signalling that the stroke of the metering piston has taken place. When pressure alternates from line 1 to line 2, the lubricant enters from hole S, pushes downwards pistons A and B and switches contact G. If required, an additional micro-switch can also be installed on the opposite side of the indicator turret, thus signalling the return stroke of the piston (fig. 3).

Maintenance.

The mechanical and electrical components of the units are not subject to particularly heavy thermal or mechanical treatment. .For spare micro-switch G, only order part no. 38031.



END OF LINE PRESSURE SWITCH

Dual Line System.

1124402
1124415
1124440
1124447

ENGLISH

PRODUCT DATA SHEET

DESCRIPTION:

This end of line pressure switch guarantees the correct operating pressure and the line inversion in dual line installations.

When lubricant pressure in the line reaches the pre-set value, the pressure switch controls, through the electric or electronic equipment, the lighting of a lamp and, if the installation is equipped with an electric controlled line pressure inverter, it drives the line inversion.

The end of line pressure switch comprises of:

- 1 sturdy block with 2 ¼" BSP inlet ports.
- 2 micro-switches.
- 2 pressure adjustment valves.
- 2 pressure gauges
- 2 air bleed valves.

Types of Pressure Switch:

Pressure switch Part No. 1124440;

Fitted at the end of the main line, checks the correct operating pressure and, for installation with hydraulic inverter, controls the inversion from Line 1 to Line 2 and vice-versa.

Pressure switch Part No. 1124415;

Same as Part No. 1124440 but mounted in a waterproof box. Protection degree IP 55.

Pressure switch Part No. 1124454;

Same as Part No. 1124415 but with explosion proof switch.



Pressure switch Part No. 1124447;

Particularly suitable for installations with many lubricant feeders and with many secondary lines.

This switch must be fitted at the end of the main line or at the end of a particularly important secondary line And is electrically connected to another pressure switch mounted on the other end of the line. If one of the two pressure switches is not activated by lubricant pressure, the electric equipment signals an alarm to stop the machine. Only if both pressure switches are acted upon by the correct lubricant pressure, the electric equipment signals the line inversion.

INSTALLATION/OPERATION:

Operation.

When lubricant pressure in the line connected to the pump, reaches the pre-set value on the pressure adjusting valve 1, piston 2, moves up to close the contact of micro-switch 5 which signals, through the lamp of the electric panel, the inversion of the line

ORDERING INFORMATION:

Ordering is by Part No. and description, please refer to the following table:

Part No.	Electrical connections	Pressure adjustment range	Operating differential pressure*	Micro-switch features
1124454	Terminal board	30 to 330 bar	16 to 20 bar	380V ac. 20A Life expectancy 10x10 ⁶ cycles Temperature range -20°C to +85°C
1124415	Terminal board	30 to 330 bar	16 to 20 bar	
1124440	Connector 3 poles + earth	30 to 330 bar	16 to 20 bar	
1124447	Connector 6 poles + earth	30 to 100 bar	12 to 14 bar	

* Operating differential pressure = difference of pressure necessary to obtain the change of micro-switch contacts.



POMAC
LUB SERVICES BVBA

Kortrijkstraat 187 B-8770 Ingelmunster

Tel. +32 (0)51 316 205 - Fax +32 (0)51 309 621 info@pomac.be - www.pomac.be

under pressure.

For dual line installations with an electrically controlled inverter, micro-switch 5 also commands the inversion of pressurization of the lines.

Note: A red alarm lamp signals any malfunction of the end of line pressure switch.

The next lubrication cycle inversion will occur in the same way as described above. The lubricant pressure in the line now connected to the pump reaches the pre-set value on the other pressure adjusting valve. The pressure in the previously pressurized line is released. This release pressure must be equal to the operating differential pressure in order to guarantee the correct delivery of lubricant from the metering valves.

The operating differential pressure is the difference in pressure necessary to open the contact of micro-switch 5, and depends on distance X between piston 2 and micro-switch 5, which must be 3,3 mm.

Adjusting valve setting:

1. Loosen nut A.
2. Turn adjusting nut B until the desired setting value is obtained (check that the pump is operating at the correct pressure by means of the pressure gauge and verify with an

Ohmmeter the change of contacts in the micro-switch).

3. Tighten nut A.
4. Repeat the same operation on the valve that controls the other lubrication line.

Note: by dismantling spring 4, maximum adjusting pressure will be 100 bar. In this case we advise the use of pressure gauge **Part No. 20606** (scale from 0 to 250 bar).

Spare parts:

Spare parts	
Description	Part No.
1. Adjusting valve assembly.	1124430
1. Adjusting valve assy. for 1124447.	1124446
2. Piston	1124423
3. Spring.	3191222
4. Spring.	3191223
5. Micro-switch.	38041
6. Pressure gauge (0 to 400 bar).	20604
6. Pressure gauge (0 to 250 bar).	20606
7. Air bleed screw.	3230103
8. screws.	12707

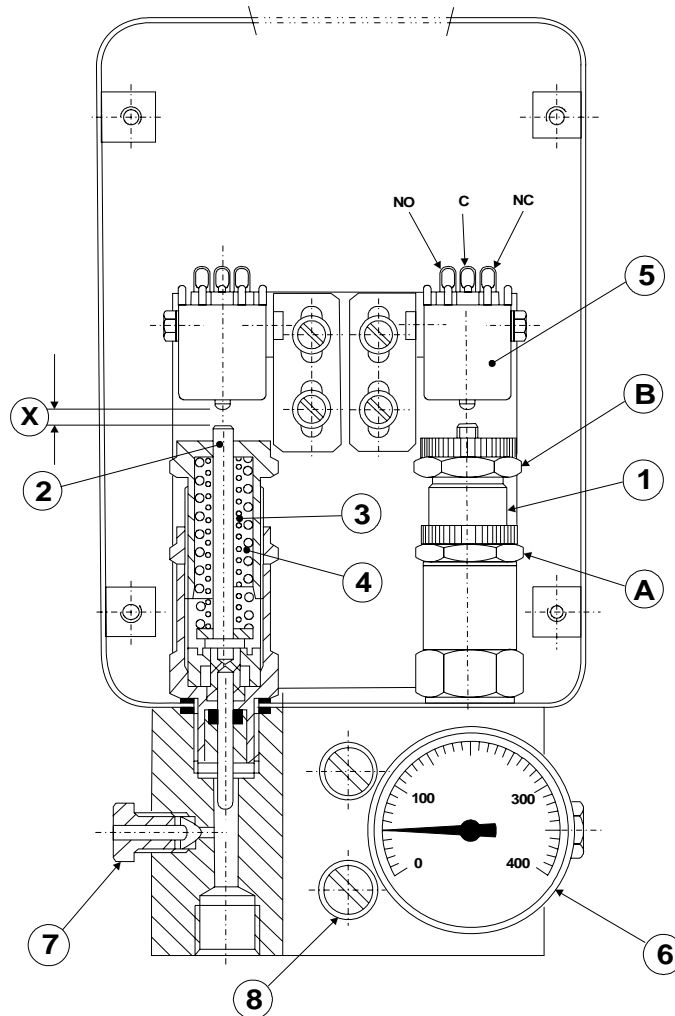

Pressure Switch Part No. 1124440 Electrical connections.

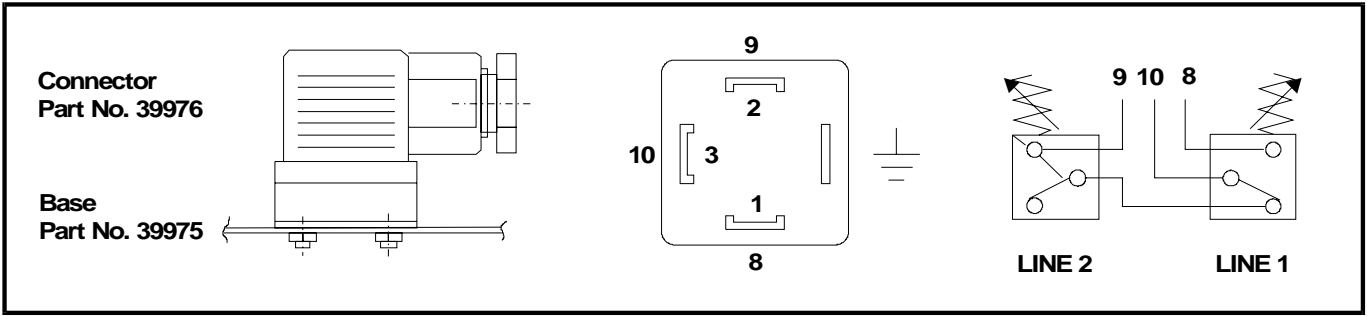

Pressure Switch Part No.'s. 1124454 – 1124415 Electrical connections.

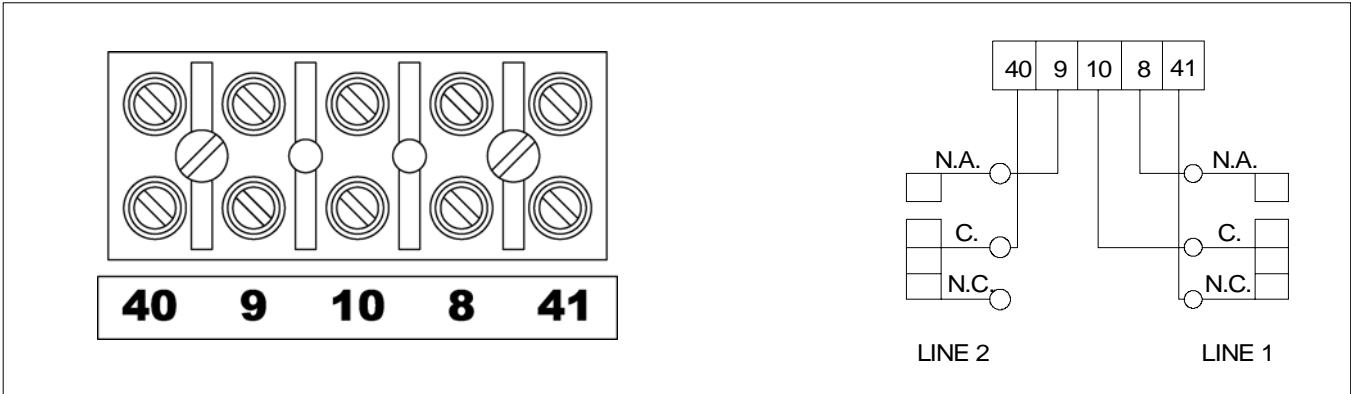

Pressure Switch Part No. 1124447 Electrical connections block diagram.

